

# Double DishDrawer Dishwasher, Sanitise

Series 9 | Contemporary

Black Stainless Steel



Wash one drawer while you load the other, with minimal bending. Or wash both at once, with room in each drawer for full size dinner plates.

- Six wash programs, as well as additional Quick wash, Sanitise and Extra Dry options
- Black stainless steel finish with black anodised aluminium handle and buttons
- Flexible racking allows you to customise internal shelves to suit your needs

- Pairs beautifully with our Black French Door Refrigerator

## DIMENSIONS

Height	820 - 880 mm
Width	599 mm
Depth	573 mm

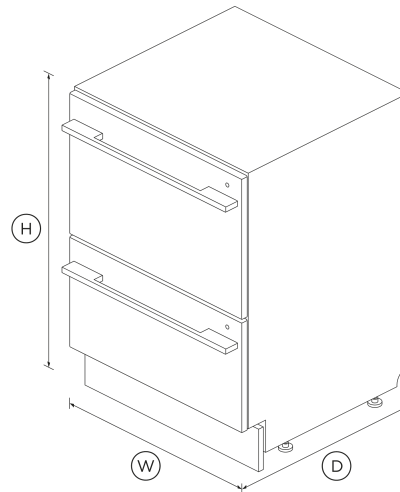

## FEATURES & BENEFITS

### Ease Of Use

DishDrawer™ Dishwashers are as easy to open and close as kitchen drawers, making loading dishes simple. Flexible racking allows you to make adjustments to fit in a variety of dishes.

### Beauty Of Choice

As much a high performance appliance as a design component, the black DishDrawer™ Dishwasher brings a touch of sophistication to your kitchen, on its own or part of a matching kitchen appliance set.

### Independent Washing

With the ability to use both drawers independently and select different wash programs, the DishDrawer™ Dishwasher can wash everything from fine glass and crystal to heavily soiled pots and pans.

### True Half Load

Each drawer holds a true half load for small, fast dish washing that won't waste water. Both drawers operate independently so two wash cycles can operate simultaneously to allow for varying loads.

### Quiet Performer

The DishDrawer™ Dishwasher does its job without making a fuss - running at a very low decibel rating, they produce little in the way of noise.

### Multiple Wash Types

Wash modifiers allow specialised cycle settings. Quick delivers faster with no performance reduction, Sanitise provides extra protection from bacteria, and Extra Dry is perfect for plastic dishes.

## SPECIFICATIONS

### Accessories (included)

Cutlery basket	•
Kickstrip	true

Knife clip and multipurpose clip •

**Capacity and loading**

Accommodates round plates up to **280mm**  
 Adjustable height, foldable cupracks •  
 Fold down tines •  
 Pitch adjustable tines •  
 Place settings **12**  
 Place settings per drawer **6**

**Consumption**

Energy rating **E**  
 Energy usage **54kWh/100 cycles per drawer**  
 Water usage (per wash cycle) **7.8L per drawer**

**Controls**

Electronic fault/Diagnostic indicator •  
 End of cycle beeps •  
 Energy saving delay start option of up to 12 hours •  
 Internal wash selector •  
 Keylock •  
 Rinse aid indicator light •  
 Smart appliance •  
 Wi-Fi connectivity •

**Features**

Built-in water softener •  
 Fan assisted drying •  
 Flood protection •  
 Flow through detergent dispenser •  
 Quiet operation •  
 SmartDrive™ technology •

**Performance**

Noise on standard cycle top drawer **42 dBA**

**Power requirements**

Amperage **10A**  
 Supply frequency **50Hz**  
 Supply voltage **220 - 240V**

**Product dimensions**

Depth **573 mm**  
 Height **820 - 880 mm**  
 Width **599 mm**

**Warranty**

Parts and labour **2 years**

**Wash Program Modifiers**

Extra Dry •  
 Quick •

Sanitise •  
 Wash modifiers **3**

**Wash Programs**

Delicate •  
 Eco •  
 Fast •  
 Heavy •  
 Medium •  
 Rinse •  
 Wash programs **6**



**Water connection**

Water pressure **100kPa - 1000kPa**  
 Water supply **3/4" BSP (20mm) Connector Water Inlet Hose**

SKU **82363**

The product dimensions and specifications in this page apply to the specific product and model. Under our policy of continuous improvement, these dimensions and specifications may change at any time. You should therefore check with Fisher & Paykel's Customer Care Centre to ensure this page correctly describes the model currently available. © Fisher & Paykel Appliances Ltd 2020

**Other product downloads available at [fisherpaykel.com](http://fisherpaykel.com)**

- [↓](#) 2D-DWG Double DishDrawer™ Dishwasher
- [↓](#) 2D-DXF Double DishDrawer™ Dishwasher
- [↓](#) Data Sheet Double DishDrawer™ Dishwasher
- [↓](#) Energy Rating
- [↓](#) Energy Rating DishDrawer™ Dishwasher EN
- [↓](#) Service & Warranty
- [↓](#) Installationsvejledning DA
- [↓](#) Installationsanleitung DE
- [↓](#) Installatie gids DUT
- [↓](#) Installation Guide Double DishDrawer™ Dishwasher
- [↓](#) Installation Guide Double DishDrawer™ Dishwasher
- [↓](#) Asennusopas FI
- [↓](#) Guide d'installation FR
- [↓](#) HE
- [↓](#) Guida D'Installazione IT
- [↓](#) Installasjonsveiledning NO
- [↓](#) Guía de instalación ES
- [↓](#) Installationsguide SV
- [↓](#) Gebruikershandleiding DUT
- [↓](#) Quick Start Guide DishDrawer™ Dishwasher EN
- [↓](#) Guía del usuario ES
- [↓](#) Quick Start Guide FIN
- [↓](#) Guide d'utilisation FR
- [↓](#) HEB
- [↓](#) Guida dell'utente ITA
- [↓](#) Wash Program Data DishDrawer™ Dishwasher
- [↓](#) Wash Program Data Sheet

All appliances use energy, and energy usage typically generates carbon emissions. **Fisher & Paykel Appliances' In-use Energy Carbon Emissions Estimate** indicates carbon emissions from a product's in-use energy. This is calculated either annually or per cycle, using the product's market-specific energy label energy consumption data multiplied by the carbon emissions factor for energy in your country or region.

Our In-use Energy Carbon Emissions Estimate is designed to assist customers in making informed purchasing decisions when comparing different Fisher & Paykel products. For example, a heat pump dryer typically has a lower In-use Energy Carbon Emissions Estimate than a vented dryer.



**A PEACE OF MIND SALE**  
**24 Hours 7 Days a Week Customer Support**  
 T 08000886605 W [www.fisherpaykel.com](http://www.fisherpaykel.com)

Where applicable: