

413L Series 5 Refrigerator Freezer, Ice & Water

Series 5 | Contemporary

Stainless Steel | Right Hinge



With stylish contemporary design and generous, flexible storage for all your chilled and frozen foods.

- ActiveSmart™ technology helps keep food fresher for longer by constantly maintaining the ideal temperature.
- Spacious bottom freezer with easy-slide internal drawers to separate storage
- Door water dispenser and internal ice maker

DIMENSIONS

Height	1715 mm
Width	680 mm
Depth	695 mm

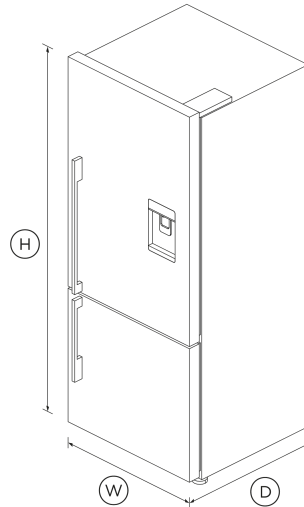

FEATURES & BENEFITS

Design Quality

Our refrigerators are designed and built using quality materials. We use real stainless steel for the finish, and solid glass for shelving.

Clever Energy

Your refrigerator adapts to daily use by cooling and defrosting only when needed. This means it uses the energy it needs without compromising on food care.

Easy Cleaning

No more permanent dirty marks with our EZKleen feature for stainless steel fridges. Anti-fingerprint coating means you simply wipe clean any marks. Spill-safe secure glass shelves easily capture any drips or leaks.

Ice Maker

Fresh ice is always available for you in a dedicated freezer bin. Simply turn it off to free up freezer space or during busy times, you can boost ice production by up to 30%.

Water On Tap

The slimline dispenser makes it easy to fill almost any sized jug or vessel with cool filtered water, and doesn't take up any storage space in your fridge.

Humidity Control

Your fruit and veges need different environments. The humidity control slides in each storage bin create a microclimate that helps keep food fresher for longer.

SPECIFICATIONS

Accessories (sold separately)

Water filter replacement	847200 - FWC3
--------------------------	---------------

Capacity

Total gross capacity	442 L
Volume	413 L
Volume freezer	119 L
Volume refrigerator	294 L

Consumption

Energy rating	3 star
---------------	--------

Energy usage **433kWh/year**
 In-use energy carbon emissions estimate **282.1kgCO2e/year**

- ActiveSmart™ Foodcare
- Adaptive defrost
- Frost free freezer
- Humidity control system
- Inverter controlled compressor

- ↓ [2D-DWG Freestanding Refrigerator Freezer](#)
- ↓ [2D-DXF Freestanding Refrigerator Freezer](#)
- ↓ [Archicad Freestanding Refrigerator Freezer](#)
- ↓ [Data Sheet Freestanding Refrigerator Freezer](#)
- ↓ [Service & Warranty](#)
- ↓ [Installation Guide](#)
- ↓ [Revit Freestanding Refrigerator Freezer](#)
- ↓ [Sketchup Freestanding Refrigerator Freezer](#)
- ↓ [User & Installation Guide ActiveSmart Refrigerator](#)

Features

Adjustable door shelves **4**
 Adjustable glass shelves **4**
 Covered door shelves **2**
 Door alarm •
 Egg trays **2**
 Fruit and vegetable bins **2**
 Full width door shelves **2**
 LED lighting •
 Single bottle holders **2**
 SmartTouch control panel •
 Ultra slim water dispenser •

Product dimensions

Depth **695 mm**
 Depth (including handles) **730 mm**
 Height **1715 mm**
 Height to top of cabinet **1715 mm**
 Minimum air clearance - each side **20 mm**
 Minimum air clearance - on top **50 mm**
 Width **680 mm**

Warranty

Sealed system parts only **additional 3 years**

SKU **26392**

The product dimensions and specifications in this page apply to the specific product and model. Under our policy of continuous improvement, these dimensions and specifications may change at any time. You should therefore check with Fisher & Paykel's Customer Care Centre to ensure this page correctly describes the model currently available. © Fisher & Paykel Appliances Ltd 2020

Where applicable:

All appliances use energy, and energy usage typically generates carbon emissions. **Fisher & Paykel Appliances' In-use Energy Carbon Emissions Estimate** indicates carbon emissions from a product's in-use energy. This is calculated either annually or per cycle, using the product's market-specific energy label energy consumption data multiplied by the carbon emissions factor for energy in your country or region.

Our In-use Energy Carbon Emissions Estimate is designed to assist customers in making informed purchasing decisions when comparing different Fisher & Paykel products. For example, a heat pump dryer typically has a lower In-use Energy Carbon Emissions Estimate than a vented dryer.



A PEACE OF MIND SALE
24 Hours 7 Days a Week Customer Support
 T 1300 650 590 **W**www.fisherpaykel.com

Performance

Other product downloads available at fisherpaykel.com