

Integrated CoolDrawer Multi-temperature Drawer

Series 9 | Integrated

Panel Ready



Designed with the flexibility to be placed anywhere in your home, you can change your CoolDrawer™ from refrigerator to pantry or freezer with the push of a button.

- Variable Temperature Zone lets you change between five different food modes - fridge, freezer, pantry, chill and wine
- Customise with your own kitchen cabinetry or purchase our stainless steel door panel accessory

DIMENSIONS

Height	640 mm
Width	855 mm
Depth	557 mm

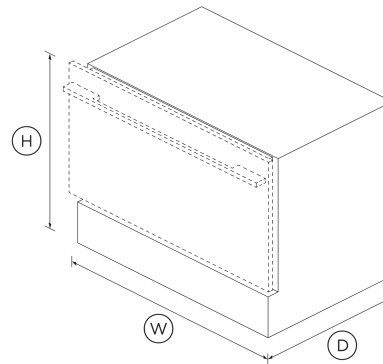

FEATURES & BENEFITS

Fridge

The ideal storage for most foods such as fruit, vegetables, dairy products and drinks. The compact upper storage tray is a perfect place for sensitive foods while the tall bin is ideal for large bottles and containers.

Pantry

Designed for foods that require a cool, dark place for storage such as tropical fruits, tomatoes and cereals.

Freezer

Ideal for general frozen food storage with the added flexibility of three freezer functions - bottle chill, fast freeze and deep freeze. Freezer mode is set at -18°C for longer term storage of frozen items.

Wine

Wine Mode is ideal for long term storage of all wine at 12°C. It also offers short term storage at 7°C for white wine and 15°C for red wine.

Chill

Chill Mode sets the compartment to a temperature ideal for highly perishable meats, poultry and seafood. Chill Mode sets the compartment at -0.5°C, just above the freezing temperature for meat.

SPECIFICATIONS

Accessories (sold separately)

Door panel set stainless steel	RD9064S
Handle kit Classic	AHCLRD90S
Handle kit Contemporary round, aluminium	AHSRB90S
Handle kit Contemporary square fine, aluminium	AHD5RD90S
Handle kit Contemporary square fine, black	AHD5RD90SB
Handle kit Professional round flush	AHP3RD90S

Capacity

Total gross capacity	123 L
Total net volume	104L
Volume	80 L

Consumption

Energy rating	E
Energy usage	82kWh/year (refrigerator mode), 197kWh/year (freezer mode)
In-use energy carbon emissions estimate	16.3kgCO ₂ e/year (refrigerator mode), 39.2kgCO ₂ e/year (freezer mode)

Variable Temp Compartment

- Chill (mode) •
- Freezer (mode) •
- Fridge (mode) •
- Pantry •
- Wine •

Warranty

- Parts and labour **5 years**
- Sealed system parts only **5 years**

SKU 26091

The product dimensions and specifications in this page apply to the specific product and model. Under our policy of continuous improvement, these dimensions and specifications may change at any time. You should therefore check with Fisher & Paykel's Customer Care Centre to ensure this page correctly describes the model currently available. © Fisher & Paykel Appliances Ltd 2020

Other product downloads available at fisherpaykel.com

- ↓ 2D-DWG Integrated CoolDrawer
- ↓ 2D-DXF Integrated CoolDrawer
- ↓ Archicad Integrated CoolDrawer
- ↓ Data Sheet Integrated CoolDrawer
- ↓ Energy Label Integrated CoolDrawer™
- ↓ Service & Warranty
- ↓ Installation Guide - Framed Cabinetry
- ↓ Installation Guide - Frameless Cabinetry

- ↓ Product Fiche
- ↓ Revit Integrated CoolDrawer
- ↓ Rhino Integrated CoolDrawer™
- ↓ Sketchup Integrated CoolDrawer
- ↓ User Guide Integrated CoolDrawer EN

Where applicable:

All appliances use energy, and energy usage typically generates carbon emissions. **Fisher & Paykel Appliances' In-use Energy Carbon Emissions Estimate** indicates carbon emissions from a product's in-use energy. This is calculated either annually or per cycle, using the product's market-specific energy label energy consumption data multiplied by the carbon emissions factor for energy in your country or region.

Our In-use Energy Carbon Emissions Estimate is designed to assist customers in making informed purchasing decisions when comparing different Fisher & Paykel products. For example, a heat pump dryer typically has a lower In-use Energy Carbon Emissions Estimate than a vented dryer.



A PEACE OF MIND SALE
24 Hours 7 Days a Week Customer Support
 T 08000 886 605 Wwww.fisherpaykel.com

Features

- Door alarm •
- Full extension runners •
- LED lighting •
- SmartTouch control panel •
- Spill proof removable bins •
- Variable temperature control •

Performance

- ActiveSmart™ Foodcare •
- Noise emissions **39 dBA**
- Noise emissions class **C**
- Quiet mark certified •

Product dimensions

- Depth **557 mm**
- Height **640 mm**
- Width **855 mm**