

Oven, 90cm, 9 Function

Series 7 | Contemporary

Stainless Steel



With a large capacity and beautiful contemporary styling, this built-in oven will complement your kitchen design perfectly.

- 100L total capacity
- Nine functions including Pastry Bake, Roast and Warm
- With built-in professional grade rotisserie
- Non-tip telescopic shelves so you can safely slide hot dishes out of the oven

DIMENSIONS

Height	478 mm
Width	895 mm
Depth	564 mm

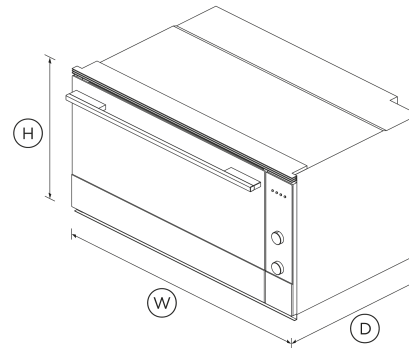

FEATURES & BENEFITS

Cooking Flexibility

This built-in oven has nine functions with pre-set temperatures, including Bake, Pastry Bake and Fan Forced, allowing you to use a variety of cooking styles.

Sized To Suit

Designed for multi-shelf cooking, this is one of the largest built-in ovens on the market providing 100L total capacity. The wide cavity allows for both side by side and multi-shelf cooking.

Easy Cleaning

This built-in oven has catalytic liners that break down oil and fat splashes during cooking so you don't have to spend hours cleaning.

Safe And Sound

The CoolTouch door with double glazing and cooling system is safe to touch from the outside, protecting your hands and the surrounding cabinetry. Getting large dishes in and out of the oven is a breeze with full telescopic sliding shelves that stay perfectly steady – even when pulled all the way out.

Perfect Results

Our built-in ovens feature AeroTech – a technology that circulates heat evenly, ideal for multi-shelf cooking.

Designed To Match

With their premium handle styling and stainless steel finish, our built-in ovens are designed to match the rest of Fisher & Paykel's kitchen appliance family.

SPECIFICATIONS

Accessories (included)

Grill rack	1 set
Roasting dish	1
Rotisserie set	1
Step down wire shelf	1
Telescopic sliding runners	1 set

Accessories (sold separately)

Handle kit Contemporary round, aluminium	Optional round handle
--	-----------------------

Capacity

Shelf positions	4
Total capacity	100 L
Usable capacity	85 L

Roast	•
Rotisserie	•
Warm	•

SKU 81675

The product dimensions and specifications in this page apply to the specific product and model. Under our policy of continuous improvement, these dimensions and specifications may change at any time. You should therefore check with Fisher & Paykel's Customer Care Centre to ensure this page correctly describes the model currently available. © Fisher & Paykel Appliances Ltd 2020

Cleaning

Acid resistant graphite enamel	•
Drop down grill element	•
Removable oven door	•
Removable oven door inner glass	•
Removable shelf runners	•

Performance

AeroTech™ technology	•
Automatic rapid pre-heat	•
Grill power	3600 W

Other product downloads available at fisherpaykel.com

- [↓](#) User Guide Built-in Oven
- [↓](#) 2D-DWG Oven
- [↓](#) 2D-DXF Oven
- [↓](#) Archicad Oven
- [↓](#) Data Sheet Oven
- [↓](#) Service & Warranty
- [↓](#) Installation Guide
- [↓](#) Revit Oven
- [↓](#) Rhino Oven
- [↓](#) Sketchup Oven
- [↓](#) User Guide

Controls

Audio feedback	•
Automatic cooking/minute timer	•
Automatic pre-set temperatures	•
Celsius/Fahrenheit temperature	•
Electronic clock	•
Electronic oven control	•
Turned stainless capacitive touch buttons with illuminated halos	•

Power requirements

Amperage	20.56 A
----------	---------

Product dimensions

Depth	564 mm
Height	478 mm
Width	895 mm

Safety

Balanced oven door	•
Catalytic venting system	•
Control panel key lock	•
CoolTouch door	•
Non-tip shelves	•

Where applicable:

All appliances use energy, and energy usage typically generates carbon emissions. **Fisher & Paykel Appliances' In-use Energy Carbon Emissions Estimate** indicates carbon emissions from a product's in-use energy. This is calculated either annually or per cycle, using the product's market-specific energy label energy consumption data multiplied by the carbon emissions factor for energy in your country or region.

Functions

Bake	•
Fan bake	•
Fan forced	•
Fan grill	•
Grill	•
Number of functions	9
Pastry Bake	•

Warranty

Parts and labour	2 years
------------------	---------

Our In-use Energy Carbon Emissions Estimate is designed to assist customers in making informed purchasing decisions when comparing different Fisher & Paykel products. For example, a heat pump dryer typically has a lower In-use Energy Carbon Emissions Estimate than a vented dryer.



A PEACE OF MIND SALE
24 Hours 7 Days a Week Customer Support
T 1300 650 590 W www.fisherpaykel.com