

# 445L Series 5 Refrigerator Freezer

Series 5 | Contemporary

Stainless Steel | Left hinge



With stylish contemporary design and large capacity, flexible storage for all your chilled and frozen foods.

- ActiveSmart™ technology to help keep food fresher for longer by stopping temperature fluctuation
- Spacious bottom freezer with full extension drawer gives easy access to frozen goods.
- Choose which side you'd like your door hinge on to suit your kitchen layout

## DIMENSIONS

Height	1715 mm
Width	790 mm
Depth	695 mm

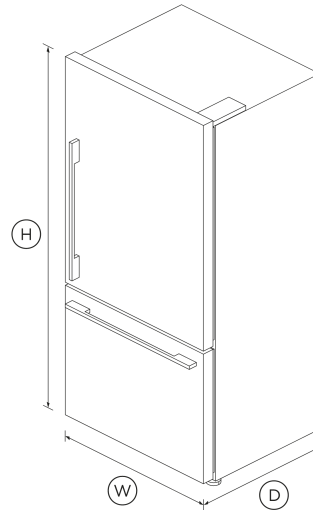

## FEATURES & BENEFITS

### Activesmart™ Foodcare

Every time you open your refrigerator, the temperature around your food changes. ActiveSmart™ foodcare adjusts airflow to create a stable temperature, helping your food stay fresher for longer.

### Design Quality

Our fridges are designed and built using quality materials. We use real stainless steel on our fridges and solid glass for shelving as well as in our wine cabinet doors.

### Easy Cleaning

No more permanent dirty marks with our EZKleen feature for stainless steel fridges. Anti-fingerprint coating means you simply wipe clean any marks. Spill-safe secure glass shelves easily capture any drips or leaks.

### Simple Storage

This refrigerator is designed to make it simple for you to store, access and remove food. Storage bins give you full access inside when they're pulled open and can be easily removed to clean. Our flexible shelving also gives you more storage options.

### Clever Energy

Your refrigerator adapts to daily use by cooling and defrosting only when needed. This means your refrigerator uses the energy it needs without compromising on food care.

## SPECIFICATIONS

### Capacity

Total gross capacity	534 L
Volume freezer	105 L
Volume refrigerator	342 L

### Consumption

Energy consumption	363kWh/year
--------------------	-------------

### Features

Adjustable door shelves	4
Adjustable glass shelves	4
Covered door shelves	2

Door alarm	•	Depth	<b>695 mm</b>
Front levelling feet	•	Height	<b>1715 mm</b>
Fruit and vegetable bins	<b>2</b>	Minimum air clearance - each side	<b>20 mm</b>
Full extension runners	•	Minimum air clearance - on top	<b>50 mm</b>
Full width door shelves	<b>2</b>	Width	<b>790 mm</b>
LED lighting	•		
Rear rollers	•		
Single bottle holders	<b>4</b>	<b>Warranty</b>	
SmartTouch control panel	•	Parts and labour	<b>2 years</b>
Stackable bottle holders	<b>4</b>	Sealed system parts only	<b>5 years</b>

**Where applicable:**

All appliances use energy, and energy usage typically generates carbon emissions. **Fisher & Paykel Appliances' In-use Energy Carbon Emissions Estimate** indicates carbon emissions from a product's in-use energy. This is calculated either annually or per cycle, using the product's market-specific energy label energy consumption data multiplied by the carbon emissions factor for energy in your country or region.

Our In-use Energy Carbon Emissions Estimate is designed to assist customers in making informed purchasing decisions when comparing different Fisher & Paykel products. For example, a heat pump dryer typically has a lower In-use Energy Carbon Emissions Estimate than a vented dryer.

**Freezer Features**

Bottle chill	•
Door alarm	•
Fast freeze	•
Large plastic bins	•

SKU 25465

The product dimensions and specifications in this page apply to the specific product and model. Under our policy of continuous improvement, these dimensions and specifications may change at any time. You should therefore check with Fisher & Paykel's Customer Care Centre to ensure this page correctly describes the model currently available. © Fisher & Paykel Appliances Ltd 2020



**A PEACE OF MIND SALE**  
**24 Hours 7 Days a Week Customer Support**  
 T +65 6741 0777 Wwww.fisherpaykel.com

**Performance**

ActiveSmart™ Foodcare	•
Adaptive defrost	•
Frost free	•
Frost free freezer	•
Humidity control system	•
Inverter controlled compressor	•
R600a refrigerant	•
Sabbath mode	•

**Other product downloads available at fisherpaykel.com**

- [↓](#) 2D-DWG Freestanding Refrigerator Freezer
- [↓](#) 2D-DXF Freestanding Refrigerator Freezer
- [↓](#) Data Sheet Freestanding Refrigerator Freezer
- [↓](#) Service & Warranty
- [↓](#) Installation Guide - Surround Kit
- [↓](#) User Guide
- [↓](#) User & Installation Guide ActiveSmart Refrigerator
- [↓](#) Installation & User Guide Refrigerator

**Product dimensions**