

60cm Series 9 Minimal Pyrolytic Oven

Series 9 | Minimal

Black Glass



A highlight of the Fisher & Paykel collection, this Minimal style oven with touchscreen guided cooking helps to ensure every dish is cooked to perfection.

- Touchscreen guided cooking capability offers helpful tips for different food types as well as full recipes
- 85L total capacity with 16 oven functions including Pastry Bake, Roast, Air Fry and Dehydrate
- A Wireless Temperature Sensor precisely monitors cooking in real time

DIMENSIONS

Height	598 mm
Width	596 mm
Depth	565 mm

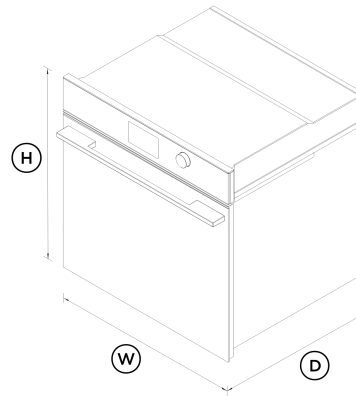

FEATURES & BENEFITS

Cook With Confidence

Using the large 5" touchscreen interface, you can cook with a favorite method, hero ingredient, cooking function or recipe. Your oven will guide you through the steps, or change the temperature and heat type automatically, depending on your selection.

Generous Capacity

With a generous 85L total capacity, you can create several perfectly cooked dishes at once using multiple shelves. Non-tip, full-extension shelves help to ensure safe removal of hot dishes.

Exceptional Performance

Our unique cooking technologies were developed to help deliver perfect results. ActiveVent ensures optimized moisture levels, while AeroTech™ circulates heat evenly for a consistent temperature.

Safe And Sound

The CoolTouch door of this built-in oven is safe to touch from the outside. Sturdy, fully extendable shelves slide all the way out, reducing the need for you to reach inside.

Self-Cleaning

Pyrolytic self-clean breaks down food residue at a very high temperature, leaving a light ash that's easily removed with a damp cloth. The enamel coated side racks don't need to be removed when using this function.

Complementary Design

Designed to blend seamlessly into the kitchen, this Minimal style oven features subtle textural and tonal contrasts. Available in a black or grey finish to support a considered kitchen design. Pair with a Warming Drawer for the ultimate kitchen solution.

Multi-Function Flexibility

Each function has been tailored, tested and perfected to ensure that no matter what you're cooking, you've got the right heat to match. Purchase our Wireless Temperature Sensor accessory and precisely monitor cooking in real time (accessory sold separately).

SPECIFICATIONS

Accessories (included)

Full extension sliding shelves	1
Grill rack	1 set
Pyrolytic proof shelf runners	•
Roasting dish	1
Smokeless grill tray	1
Step down wire shelf	1
Wired temperature sensor	1

Capacity

Shelf positions	6
Total capacity	85 L
Usable capacity	72 L

Cleaning

Acid resistant graphite enamel	•
Pyrolytic proof shelf runners	•
Pyrolytic self-clean	•
Removable oven door	•
Removable oven door inner glass	•
Removable shelf runners	•

Consumption

Energy rating	A+
Energy usage	0.89kWh/cycle

Controls

Adjustable audio and display settings	•
---------------------------------------	---

Audio feedback	•
Automatic cooking/minute timer	•
Automatic pre-set temperatures	•
Celsius/Fahrenheit temperature	•
Delay start	•
Electronic clock	•
Electronic oven control	•
Food probe	•
Guided cooking by food type and recipes	•
Halogen lights	•
Intuitive touchscreen display	•
Multi-language display	•

UK English, US English, Simplified Chinese, Français, Español

Sabbath mode with Federation of Synagogues certification	•
Smart appliance	•
Soft close doors	•
Turned stainless steel dials with illuminated halos	•
Wireless temperature sensor compatible	•

Functions

Air fry	•
Bake	•
Classic bake	•
Dehydrate	•
Fan bake	•
Fan forced	•
Fan grill	•
Grill	•

Number of functions	16
Pastry Bake	•
Pizza bake	•
Pyrolytic self-clean	•
Rapid proof	•
Roast	•
Slow cook	•
Vent bake	•
Warm	•

Performance

ActiveVent™ system	•
AeroTech™ technology	•
Automatic rapid pre-heat	•
Grill power	3000 W
Temperature range	35°C - 280°C
Whisper quiet cooking	•

Power requirements

Amperage	15 A
Supply frequency	50 Hz
Supply voltage	220 - 240 V

Product dimensions

Depth	565 mm
Height	598 mm
Width	596 mm

Safety

- Balanced oven door •
- Catalytic venting system •
- Control panel key lock •
- CoolTouch door •
- Non-tip shelves •
- Safety thermostat •

Warranty

Parts and labour **5 years**

SKU 82509

The product dimensions and specifications in this page apply to the specific product and model. Under our policy of continuous improvement, these dimensions and specifications may change at any time. You should therefore check with Fisher & Paykel's Customer Care Centre to ensure this page correctly describes the model currently available. © Fisher & Paykel Appliances Ltd 2020

Other product downloads available at fisherpaykel.com

- ↓ 2D-DWG Oven
- ↓ 2D-DXF Oven
- ↓ Declaration of Conformity Oven with WiFi Capability
- ↓ Energy Rating
- ↓ Service & Warranty
- ↓ Installation Guide DA
- ↓ Installation Guide DEU
- ↓ Installation Guide DUT

- ↓ Installation Guide Wall Oven
- ↓ Installation Guide FIN
- ↓ Installation Guide FR
- ↓ Installation Guide HEB
- ↓ Installation Guide ITA
- ↓ Installation Guide NOR
- ↓ Installation Guide SWE
- ↓ Planning Guide EN - 60cm Ovens and Companions - Minimal
- ↓ Product Information Sheet Oven
- ↓ Revit 19
- ↓ Rhino Wall Oven
- ↓ SketchUp Wall Oven
- ↓ User Guide DA
- ↓ User Guide DEU
- ↓ User Guide DUT
- ↓ User Guide Oven EN
- ↓ User Guide FIN
- ↓ User Guide FR
- ↓ User Guide HEB
- ↓ User Guide ITA
- ↓ User Guide NOR
- ↓ User Guide SWE

Where applicable:

All appliances use energy, and energy usage typically generates carbon emissions. **Fisher & Paykel Appliances' In-use Energy Carbon Emissions Estimate** indicates carbon emissions from a product's in-use energy. This is calculated either annually or per cycle, using the product's market-specific energy label energy consumption data multiplied by the carbon emissions factor for energy in your country or region.

Our In-use Energy Carbon Emissions Estimate is designed to assist customers in making informed purchasing decisions when comparing different Fisher & Paykel products. For example, a heat pump dryer typically has a lower In-use Energy Carbon Emissions Estimate than a vented dryer.



A PEACE OF MIND SALE
24 Hours 7 Days a Week Customer Support
 T 08000886605 Wwww.fisherpaykel.com