

# 413L Series 5 Refrigerator Freezer

Series 5 | Contemporary

Stainless Steel | Right Hinge

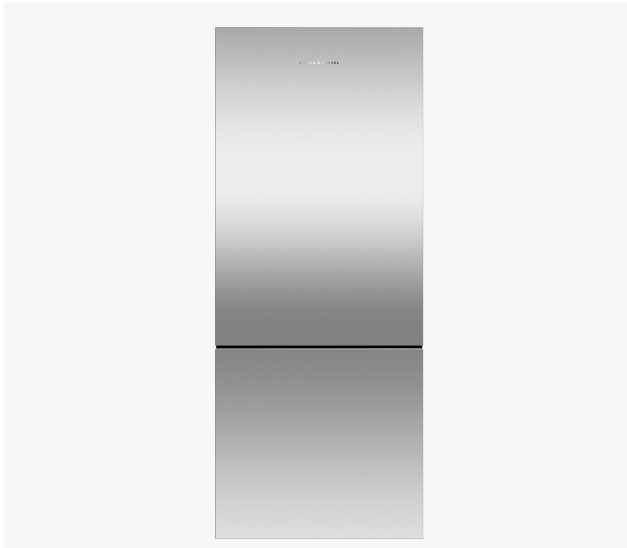

With Contemporary styling and generous, flexible storage for all your chilled and frozen foods.

- ActiveSmart™ technology helps keep food fresher for longer by constantly maintaining the ideal temperature.
- Spacious bottom freezer with easy-slide internal drawers to separate storage

## DIMENSIONS

Height	1720 mm
Width	680 mm
Depth	695 mm

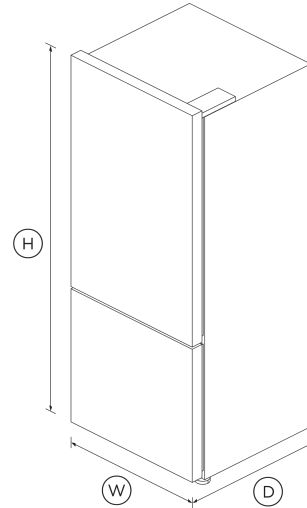

## FEATURES & BENEFITS

### Easy cleaning

No more permanent dirty marks with our EZKleen feature for stainless steel fridges. Anti-fingerprint coating means you simply wipe clean any marks. Spill-safe secure glass shelves easily capture any drips or leaks.

### Simple Storage

This refrigerator is designed to make it simple for you to store, access and remove food. Storage bins give you full access inside when they're pulled open and can be easily removed to clean. Our flexible shelving also gives you more storage options.

### Design Quality

Our fridges are designed and built using quality materials. We use real stainless steel on our fridges and solid glass for shelving as well as in our wine cabinet doors.

### Clever Energy

Your refrigerator adapts to daily use by cooling and defrosting only when needed. This means it uses the energy it needs without compromising on food care.

### Easy Living

These refrigerators adapt to suit your lifestyle with accessible SmartTouch controls, flexible shelving and storage options, and slide-out bins and trays.

### Easy Cleaning

Removable, spill-safe glass shelves are easy to clean and contain drips and spills. Storage bins and EZKleen stainless steel doors just need a wipe to keep spotless.

### Humidity Control

Your fruit and veges need different environments. The humidity control slides in each storage bin create a microclimate that helps keep food fresher for longer.

## SPECIFICATIONS

### Capacity

Total gross capacity	442 L
Volume	413 L
Volume freezer	119 L
Volume refrigerator	294 L

### Consumption

Energy rating	3 star
---------------	--------

Energy usage	<b>428kWh/year</b>
In-use energy carbon emissions estimate	<b>278.8kgCO<sub>2</sub>e/year</b>

- Humidity control system
- Inverter controlled compressor

**Features**

Adjustable door shelves	<b>4</b>
Adjustable glass shelves	<b>4</b>
Covered door shelves	<b>2</b>
Door alarm	•
Front levelling feet	•
Fruit and vegetable bins	<b>2</b>
LED lighting	•
Rear rollers	•
Single bottle holders	<b>2</b>
SmartTouch control panel	•

**Product dimensions**

Depth	<b>695 mm</b>
Height	<b>1720 mm</b>
Height to top of cabinet	<b>1720 mm</b>
Minimum air clearance - at rear	<b>30 mm</b>
Minimum air clearance - each side	<b>20 mm</b>
Minimum air clearance - on top	<b>50 mm</b>
Width	<b>680 mm</b>

**Variable Temp Compartment**

- Bottle chill mode

**Freezer Features**

Bottle chill	•
Door alarm	•
Fast freeze	•
Ice trays	<b>2</b>
Large plastic bins	•
Slide Out Pastry Tray	•
Small plastic bins	•

**Warranty**

Parts and labour	<b>2 years</b>
Sealed system parts only	<b>additional 3 years</b>

SKU 26380

The product dimensions and specifications in this page apply to the specific product and model. Under our policy of continuous improvement, these dimensions and specifications may change at any time. You should therefore check with Fisher & Paykel's Customer Care Centre to ensure this page correctly describes the model currently available. © Fisher & Paykel Appliances Ltd 2020

**Performance**

- ActiveSmart™ Foodcare
- Adaptive defrost
- Frost free freezer

**Other product downloads available at fisherpaykel.com**

- ↓ 2D-DWG Freestanding Refrigerator Freezer
- ↓ 2D-DXF Freestanding Refrigerator Freezer
- ↓ Data Sheet Freestanding Refrigerator Freezer
- ↓ Service & Warranty
- ↓ Installation Guide
- ↓ User & Installation Guide ActiveSmart Refrigerator

**Where applicable:**

All appliances use energy, and energy usage typically generates carbon emissions. **Fisher & Paykel Appliances' In-use Energy Carbon Emissions Estimate** indicates carbon emissions from a product's in-use energy. This is calculated either annually or per cycle, using the product's market-specific energy label energy consumption data multiplied by the carbon emissions factor for energy in your country or region.

Our In-use Energy Carbon Emissions Estimate is designed to assist customers in making informed purchasing decisions when comparing different Fisher & Paykel products. For example, a heat pump dryer typically has a lower In-use Energy Carbon Emissions Estimate than a vented dryer.



**A PEACE OF MIND SALE**  
**24 Hours 7 Days a Week Customer Support**  
 T 1300 650 590 **W**www.fisherpaykel.com