

# Insert Range Hood, 30"

Series 9 | Integrated

Stainless Steel

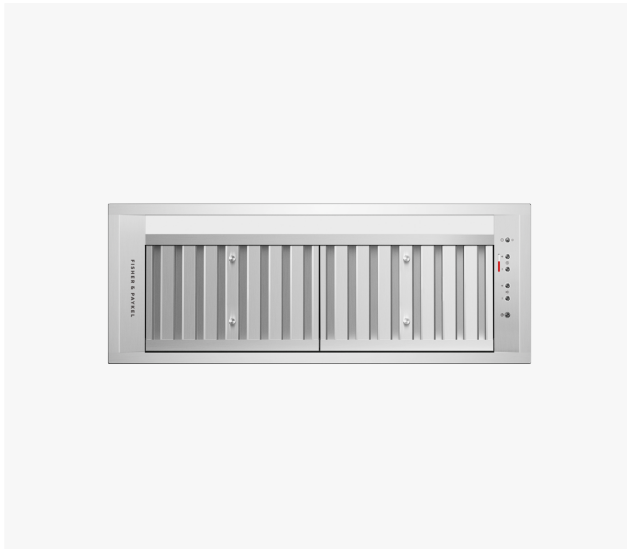

With edge-to-edge extraction, this efficient, stylish range hood is perfectly hidden away in your cabinetry.

- With five fan speeds, select the perfect extraction rate for your cooking
- With dimmable LED strip lighting
- 400CFM maximum airflow
- Dishwasher safe filters that are easy to remove and clean

## DIMENSIONS

Height	16 1/4 "
Width	28 3/4 "
Depth	11 "

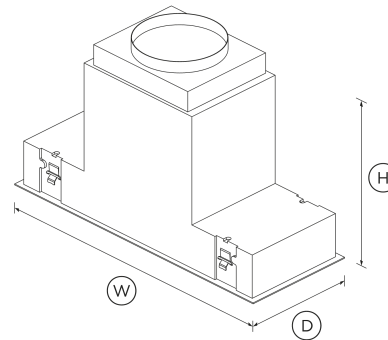

## FEATURES & BENEFITS

### Achieve The Invisible

This high quality integrated range hood seamlessly blends behind cabinetry in a variety of kitchen layouts. Beautiful in its simplicity, this product has brushed finished surfaces with no visible screws.

### Edge To Edge Extraction

Filters effectively reach edge to edge, which maximizes the amount of extraction area.

### Full Surface Lighting

The even lighting provides full coverage of the cooktop, illuminating food in its true color, with no hot or dark spots and no glare or shadows. The dimmable lights have fade in and fade out features.

### Easy To Use

This easy to use range hood operates with fingertip control of LED-illuminated soft touch buttons.

### Energy Efficiency

Powered by a brushless DC motor, the Insert Range Hood operates more efficiently, more reliably and with less noise than units with AC motors. Plus, fewer moving parts mean less erosion and longer lifetime.

### Effortless Cleaning

The stainless steel filters are easy to remove and are dishwasher safe. A self-contained grease tray within the filters makes them very easy to clean.

### Simple Installation

The simple installation process is compatible with most precut cabinetry. The adjustable mounting system can be installed with 5/8" to 9/16" cabinetry board.

## SPECIFICATIONS

### Fan ratings

Maximum air movement	400 CFM
Maximum speed sound rating	6.5 sones
Speed 1 sound rating	1.5 sones

### Installation and cleaning

Air outlet size	8 "
Dishwasher safe filters	2

Ducted **Vertical only**

SKU 50094

**Performance**

Extraction type **Surface**  
 Fan speeds **5**  
 Filter type **Stainless Steel Baffle**

The product dimensions and specifications in this page apply to the specific product and model. Under our policy of continuous improvement, these dimensions and specifications may change at any time. You should therefore check with Fisher & Paykel's Customer Care Centre to ensure this page correctly describes the model currently available. © Fisher & Paykel Appliances Ltd 2020

Our In-use Energy Carbon Emissions Estimate is designed to assist customers in making informed purchasing decisions when comparing different Fisher & Paykel products. For example, a heat pump dryer typically has a lower In-use Energy Carbon Emissions Estimate than a vented dryer.



**A PEACE OF MIND SALE**  
**24 Hours 7 Days a Week Customer Support**  
 T 1.888.936.7872 W www.fisherpaykel.com

**Power requirements**

Supply voltage **120 V**

**Other product downloads available at fisherpaykel.com**

- [↓ 2D-DWG Insert Rangehood](#)
- [↓ 2D-DXF Insert Rangehood](#)
- [↓ Archicad Insert RangeHood](#)
- [↓ Data Sheet Insert Rangehood](#)
- [↓ Service & Warranty](#)
- [↓ Installation Guide EN / Guide d'installation FR](#)
- [↓ Revit Insert RangeHood](#)
- [↓ Rhino Insert RangeHood](#)
- [↓ Sketchup Insert RangeHood](#)
- [↓ User Guide EN / Guide d'utilisation FR](#)

**Product dimensions**

Depth **11 "**  
 Height **16 1/4 "**  
 Width **28 3/4 "**

**Product information**

Control type **Electronic**

**Where applicable:**

All appliances use energy, and energy usage typically generates carbon emissions. **Fisher & Paykel Appliances' In-use Energy Carbon Emissions Estimate** indicates carbon emissions from a product's in-use energy. This is calculated either annually or per cycle, using the product's market-specific energy label energy consumption data multiplied by the carbon emissions factor for energy in your country or region.

**Ventilation features**

Auto-off/Run-on timer •  
 Dimmable lights •  
 Filter cleaning alert •  
 Light type **LED**  
 Number of light settings **5**  
 Simple sensing •