

# 9kg Series 9 Heat Pump Dryer

Series 9 | Heat pump

White



Better energy efficiency and fabric care with heat pump condensing technology, which dries your clothes at a lower temperature.

- 18 dry cycles, including 5 extra care cycles
- 8 Star Energy Rating
- Auto-sensing detects moisture levels to prevent under or over drying

- No need for external venting, allowing your dryer to be placed anywhere in your home

## DIMENSIONS

Height	850 mm
Width	600 mm
Depth	670 mm

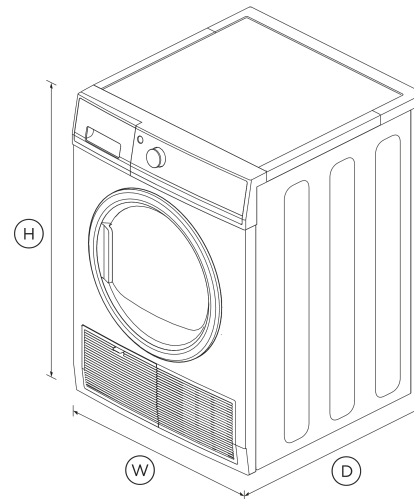

## FEATURES & BENEFITS

### 18 Fabric Care Cycles

Intuitive controls with clever drying hints help you get the best results. Easy to use, the LCD display provides a simple interface to select from 18 dry cycles; including Ultra-delicate for lace; Outdoor for high performance fabrics; a Warm-up cycle for towels; Jeans for everyday essentials; and Soft Toys for those special items.

### Heat Pump Technology

Heat pump technology dries at lower temperatures for gentle fabric care and because moisture is condensed, no venting is required. This is an ideal dryer for laundries where venting is difficult as it can be placed almost anywhere in the home.

### Auto-Sensing Technology

Auto-sensing technology measures moisture inside the drum, shutting off at the perfect time to avoid over-drying your clothes, helping them last longer and reducing energy wastage.

### 8 Star Energy Rating

This dryer uses heat pump technology to gently and effectively dry clothes at low temperatures, and achieves an outstanding 8 star energy rating

### Too Precious To Tumble?

The drying rack is designed for items that can't be tumble dried. It fits easily into the dryer and delivers the perfect result for those precious delicates, shoes and toys.

### Designed To Match

The Heat Pump Condensing Dryer is designed to match beautifully with any Fisher & Paykel front loader washing machine, creating the perfect pair to deliver complete fabric care.

## SPECIFICATIONS

### Capacity

Total capacity **9 kg**

### Consumption

Energy rating **5 ticks**  
Energy usage **306kWh/year**

In-use energy carbon emissions estimate **117.3kgCO2e/year**

**Dry Cycles**

- Bulky •
- Cool air •
- Delicate •
- Easy Iron •
- Everyday •
- Heavy •
- Jeans •
- Number of cycles **18**
- Outdoor •
- Rack dry •
- Sheets •
- Soft toys •
- Sports •
- Time dry •
- Towels •
- Ultra Delicate •
- Warm up •
- Wool •

- Drying rack •
- Easy access lint filter •
- Easy clean condenser filter •
- End of cycle signal •
- Favourite mode •
- LCD screen •
- No external venting •
- Progress indicator •
- Removable water tank •
- Screen brightness settings •
- SmartTouch™ control dial •
- Stainless steel drum •
- Time to go •
- Wrinkle free option •

**Performance**

- Auto sensing •
- Dryness settings **5**
- Heat pump technology •
- Reverse tumbling •
- Time dry **30,40,50... 150 mins**

**Product dimensions**

- Depth **670 mm**
- Height **850 mm**
- Width **600 mm**

**Warranty**

Parts and labour **2 years**

SKU **93273**

The product dimensions and specifications in this page apply to the specific product and model. Under our policy of continuous improvement, these dimensions and specifications may change at any time. You should therefore check with Fisher & Paykel's Customer Care Centre to ensure this page correctly describes the model currently available. © Fisher & Paykel Appliances Ltd 2020

**Other product downloads available at fisherpaykel.com**

[↓ Service & Warranty](#)

**Where applicable:**

All appliances use energy, and energy usage typically generates carbon emissions. **Fisher & Paykel Appliances' In-use Energy Carbon Emissions Estimate** indicates carbon emissions from a product's in-use energy. This is calculated either annually or per cycle, using the product's market-specific energy label energy consumption data multiplied by the carbon emissions factor for energy in your country or region.

Our In-use Energy Carbon Emissions Estimate is designed to assist customers in making informed purchasing decisions when comparing different Fisher & Paykel products. For example, a heat pump dryer typically has a lower In-use Energy Carbon Emissions Estimate than a vented dryer.



**A PEACE OF MIND SALE**

24 Hours 7 Days a Week Customer Support

T +65 6741 0777 W [www.fisherpaykel.com](http://www.fisherpaykel.com)