

# Double DishDrawer Dishwasher, Sanitise

Series 9 | Contemporary

Stainless Steel



Wash one drawer while you load the other, with room in each drawer for full-size dinner plates.

- Designed to be installed under your benchtop, with recessed handles for a seamless look
- Six wash programs, as well as additional Quick wash, Sanitise and Extra Dry modifiers
- Flexible racking allows you to customise internal shelves to suit your needs

- Wi-Fi enabled and works with the SmartHQ™ app for remote control and notifications

## DIMENSIONS

Height	820 - 880 mm
Width	599 mm
Depth	573 mm

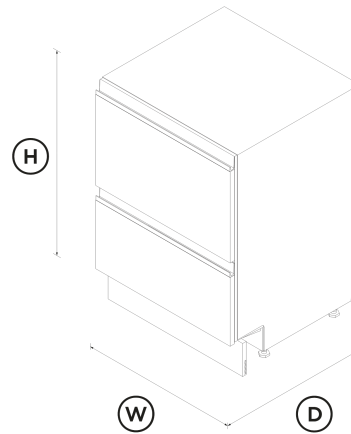

## FEATURES & BENEFITS

### Seamless Fit

Our built-under DishDrawer™ Dishwashers are installed flush under your benchtop with the option of a custom kickstrip, ensuring minimal gaps. The touch-sensitive control panel is located inside this model, leaving an uninterrupted exterior. Designed to match the Fisher & Paykel family of kitchen appliances with recessed handles for a streamlined look.

### Ease Of Use

DishDrawer™ Dishwashers are as easy to open and close as kitchen drawers and can be conveniently positioned at bench height for ease of loading and minimal bending. Flexible racking allows you to make adjustments to fit in a variety of dishes.

### Quick, Sanitise And Extra Dry Options

The Quick wash modifier delivers a faster wash while maintaining performance. The Sanitise option provides extra protection, killing 99.9% of bacteria\* in the final rinse. The Extra Dry setting is perfect for plastic dishes.

\*Certified to NSF/ANSI Standard 184

### True Half Load

Each drawer holds a true half load for small, fast washing that won't waste water. Both drawers operate independently so two wash cycles can operate simultaneously to allow for varying loads.

### Knock To Pause

For ease-of-use, these DishDrawer™ Dishwashers have a knock to pause function. A knock on the front panel will pause the dishwasher, which can be restarted by using the start button.

### Independent Wash

With the ability to use both drawers independently and select different wash programs, the DishDrawer™ Dishwasher can wash everything from fine glass and crystal to heavily soiled pots and pans.

### Quiet Performer

Running at a very low decibel rating, these DishDrawer™ Dishwashers do their job without making a fuss. The combination of intelligent technology and simple mechanics means greater reliability and excellent wash performance.

## SPECIFICATIONS

<b>Accessories (included)</b>		Keylock	•	Width	<b>599 mm</b>
Cutlery basket	•	Knock to pause	•		
Kickstrip	<b>true</b>	Rinse aid indicator light	•		
Knife clip and multipurpose clip	•	Smart appliance	•	<b>Warranty</b>	
		Wi-Fi connectivity	•	Parts and labour	<b>5 years</b>
<b>Capacity and loading</b>		<b>Features</b>		<b>Wash Program Modifiers</b>	
Accommodates round plates up to	<b>280mm</b>	Built-in water softener	•	Extra Dry	•
Adjustable height, foldable cupracks	•	Fan assisted drying	•	Quick	•
Fold down tines	•	Flood protection	•	Sanitise	•
Pitch adjustable tines	•	Flow through detergent dispenser	•	Wash modifiers	<b>3</b>
Place settings	<b>12</b>	Motor type	<b>BLDC</b>		
Place settings	<b>12</b>	Quiet operation	•	<b>Wash Programs</b>	
Place settings per drawer	<b>6</b>	SmartDrive™ technology	•	Delicate	•
Place settings per drawer	<b>6</b>			Eco	•
<b>Consumption</b>		<b>Performance</b>		Fast	•
Energy rating	<b>E</b>	Noise on standard cycle top drawer	<b>42 dBA</b>	Heavy	•
Energy usage	<b>54kWh/100 cycles per drawer</b>			Medium	•
In-use energy carbon emissions estimate	<b>10.7kgCO2e/100 cycles per drawer</b>	<b>Power requirements</b>		Rinse	•
Water usage (per wash cycle)	<b>7.8L per drawer</b>	Amperage	<b>10A</b>	Wash programs	<b>6</b>
		Rated current	<b>8.5 A</b>		
<b>Controls</b>		Supply frequency	<b>50Hz</b>	<b>Water connection</b>	
Energy saving delay start option of up to 12 hours	•	Supply voltage	<b>220 - 240V</b>	Water pressure	<b>100kPa - 1000kPa</b>
Internal wash selector	•	<b>Product dimensions</b>		Water supply	<b>3/4" BSP (20mm) Connector Water Inlet Hose</b>
Intuitive capacitive touch controls	•	Depth	<b>573 mm</b>		
		Height	<b>820 - 880 mm</b>		
				SKU	<b>82894</b>

The product dimensions and specifications in this page apply to the specific product and model. Under our policy of continuous improvement, these dimensions and specifications may change at any time. You should therefore check with Fisher & Paykel's Customer Care Centre to ensure this page correctly describes the model currently available. © Fisher & Paykel Appliances Ltd 2020



**A PEACE OF MIND SALE**  
**24 Hours 7 Days a Week Customer Support**  
T 08000 886 605 W [www.fisherpaykel.com](http://www.fisherpaykel.com)

#### Other product downloads available at [fisherpaykel.com](http://fisherpaykel.com)

- [↓ Declaration of Conformity Double DishDrawer™ Dishwasher](#)
- [↓ Energy Label DishDrawer™ Dishwasher](#)
- [↓ Service & Warranty](#)
- [↓ Installation Guide Double DishDrawer™ Dishwasher](#)
- [↓ Product Information Sheet Double DishDrawer™ Dishwasher](#)
- [↓ Preliminary Specification Guide Double DishDrawer™ Dishwasher](#)
- [↓ User Guide DishDrawer™ Dishwasher](#)
- [↓ Wash Program Data DishDrawer™ Dishwasher](#)

#### Where applicable:

All appliances use energy, and energy usage typically generates carbon emissions. **Fisher & Paykel Appliances' In-use Energy Carbon Emissions Estimate** indicates carbon emissions from a product's in-use energy. This is calculated either annually or per cycle, using the product's market-specific energy label energy consumption data multiplied by the carbon emissions factor for energy in your country or region.

Our In-use Energy Carbon Emissions Estimate is designed to assist customers in making informed purchasing decisions when comparing different Fisher & Paykel products. For example, a heat pump dryer typically has a lower In-use Energy Carbon Emissions Estimate than a vented dryer.