

10kg Series 5 Top Loader Washer

Series 5 | Top load

White



With plenty of room for large loads, and 6 wash cycles including Allergy, this top loader caters to every type of load.

- SmartDrive™ technology delivers a gentle, quiet and reliable wash
- Six wash cycles including Allergy, Easy Iron and Handwash
- Soft-close lid for hands-free operation
- 4 star energy and 3.5 star water rating

DIMENSIONS

Height	1060 - 1090 mm
Width	685 mm
Depth	700 mm

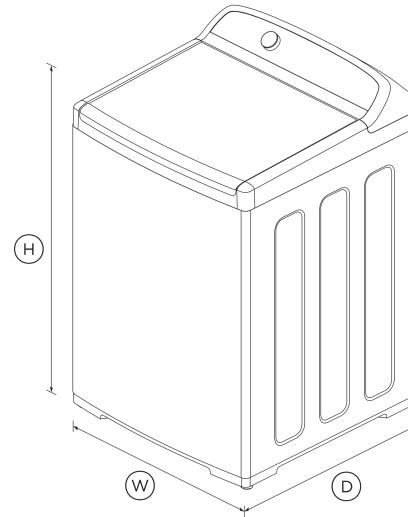

FEATURES & BENEFITS

Easy To Use

This machine has a cycle to suit every type of load including Allergy, Easy Iron and Handwash. Select a cycle with easy-to-use SmartTouch™ controls.

Cares For Clothes

The flexible finned agitator ensures less tangling for superior clothes care.

Soft Close Lid

The robust plastic lid has a soft close mechanism that makes it family safe, avoids slamming and allows for hands-free operation.

Save Time With Large Capacity

The 10kg capacity top loader is ideal for larger families and can wash bulky items with ease.

Quicker Drying

Drying times are reduced due to a fast spin speed of 1100RPM which helps remove more water.

Energy Saving

Eco-Active™ recirculates water and detergent through clothes so less hot water is used to remove stains, dirt and bacteria.

SPECIFICATIONS

Capacity

Capacity	10 kg
----------	-------

Consumption

Energy rating	4 star
Energy usage	350kWh/year
In-use energy carbon emissions estimate	228.0kgCO2e/year
Water consumption per cycle	123L
Water rating	3.5 star (WELS)

Features

Agitator	Flexible finned
Auto out of balance correction	•
Automatic water level	•

Controlled cold	•
Delay start	•
Detergent dispenser	•
Fabric softener dispenser	•
Lid lock	•
No Spin / Spin hold	•
Rinse options	3
SmartTouch™ control dial	•
Soak	•
Spin speeds	3
Stainless steel drum	•
Water temperature controls	5

Parts only SmartDrive™ motor **10 years**

Wash Cycles

Allergy	•
Handwash	•
Heavy	•
Number of wash cycles	6
Quick	•
Regular	•

SKU 92282

The product dimensions and specifications in this page apply to the specific product and model. Under our policy of continuous improvement, these dimensions and specifications may change at any time. You should therefore check with Fisher & Paykel's Customer Care Centre to ensure this page correctly describes the model currently available. © Fisher & Paykel Appliances Ltd 2020

Other product downloads available at fisherpaykel.com

- [↓](#) Energy & Water Label
- [↓](#) Service & Warranty
- [↓](#) Installation Guide
- [↓](#) User Guide

Where applicable:

All appliances use energy, and energy usage typically generates carbon emissions. **Fisher & Paykel Appliances' In-use Energy Carbon Emissions Estimate** indicates carbon emissions from a product's in-use energy. This is calculated either annually or per cycle, using the product's market-specific energy label energy consumption data multiplied by the carbon emissions factor for energy in your country or region.

Our In-use Energy Carbon Emissions Estimate is designed to assist customers in making informed purchasing decisions when comparing different Fisher & Paykel products. For example, a heat pump dryer typically has a lower In-use Energy Carbon Emissions Estimate than a vented dryer.



A PEACE OF MIND SALE
24 Hours 7 Days a Week Customer Support
 T 1300 650 590 [Wwww.fisherpaykel.com](http://www.fisherpaykel.com)

Performance

Auto-Lint disposal	•
Load sensing	•
Maximum spin speed	1100 rpm
Number of spin speeds	3
SmartDrive™ technology	•

Product dimensions

Depth	700 mm
Height	1060 - 1090 mm
Height (Lid open)	1440 - 1470mm
Width	685 mm

Warranty

Parts and labour	2 years
------------------	---------