

Front Loader Washing Machine, 9kg

Series 3 | Front Load

White



This front loader cares for all kinds of fabrics, with a cycle for everything from delicates to bulky items.

- Nine wash cycles including Quick, Delicate and Heavy
- Vortex Wash helps deliver a 30 minute Quick cycle without compromising fabric care

DIMENSIONS

Height	850 mm
Width	600 mm
Depth	655 mm

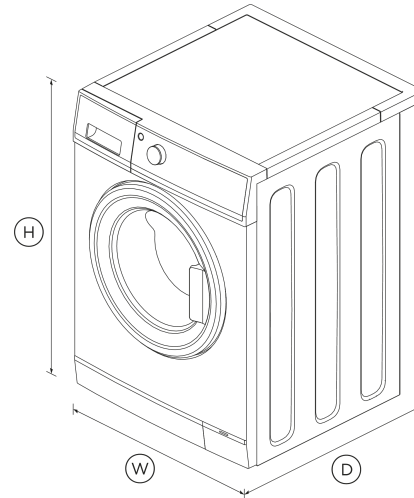

FEATURES & BENEFITS

Nine Fabric Care Cycles

Featuring nine specially-developed wash cycles to care for your clothes, this machine has a cycle to suit every load type from Heavy to Delicate.

Easy To Use

This washing machine features an intuitive control panel, where you can easily select your preferred cycle and wash boost options, which include Rinse+ and Pre Wash.

A Smarter, Quieter Motor

SmartDrive™ Technology is a gentle, quiet, and efficient combination of smart electronics and a direct drive motor that senses the load to deliver better fabric care.

Quick Cycles

When time is short, you can select a quick 30-minute wash without compromising cleaning and fabric care. Vortex Wash allows most cycles to take less than one hour to complete.

Saves Water

With a 3-tick water rating, our 9kg washing machine handles large loads while keeping water usage to a minimum.

Designed To Match

The complete package for a beautiful laundry. This washing machine is designed to match both the 8kg Heat Pump Condensing Dryer and the 8kg Condensing Dryer. With outstanding aesthetics and complementary wash and dry cycles, they become the perfect pair to deliver complete fabric care.

SPECIFICATIONS

Capacity

Capacity **9 kg**

Consumption

Water consumption per cycle **7.3L/kg**
 Water efficiency (WELS) rating **3 ticks**

Features

- Anti-fungal door gasket
- Auto out of balance correction

Child/Keylock	•	Delicate	•
Delay start	•	Drum Clean	•
Extra rinse option	•	Easy Iron	•
Flood protection	•	Everyday	•
No Spin / Spin hold	•	Heavy	•
Pre Wash	•	Number of wash cycles	9
SmartTouch™ control dial	•	Quick 30	•
Stainless steel drum	•	Rinse	•
Water temperature controls	5	Spin	•

All appliances use energy, and energy usage typically generates carbon emissions. **Fisher & Paykel Appliances' In-use Energy Carbon Emissions Estimate** indicates carbon emissions from a product's in-use energy. This is calculated either annually or per cycle, using the product's market-specific energy label energy consumption data multiplied by the carbon emissions factor for energy in your country or region.

Our In-use Energy Carbon Emissions Estimate is designed to assist customers in making informed purchasing decisions when comparing different Fisher & Paykel products. For example, a heat pump dryer typically has a lower In-use Energy Carbon Emissions Estimate than a vented dryer.

Performance

Maximum spin speed	1200 rpm
Number of spin speeds	3
SmartDrive™ technology	•
Vortex wash	•

SKU 95148

The product dimensions and specifications in this page apply to the specific product and model. Under our policy of continuous improvement, these dimensions and specifications may change at any time. You should therefore check with Fisher & Paykel's Customer Care Centre to ensure this page correctly describes the model currently available. © Fisher & Paykel Appliances Ltd 2020



A PEACE OF MIND SALE
24 Hours 7 Days a Week Customer Support
 T +65 6741 0777 W www.fisherpaykel.com

Product dimensions

Depth	655 mm
Height	850 mm
Width	600 mm

Other product downloads available at fisherpaykel.com

- [↓ Service & Warranty](#)
- [↓ Installation Guide](#)
- [↓ Installation Guide - Cavity Sizes](#)
- [↓ User Guide](#)

Warranty

Parts and labour	2 years
Parts only direct drive motor	8 years

Where applicable:

Wash Cycles

Cottons	•
---------	---