

30" Series 7 Contemporary Compact Combi-Steam Oven

Series 7 | Contemporary

Stainless Steel

Designed for the home chef, our Combination Steam Oven simplifies the creation of healthy and delicious meals. It pairs seamlessly with companion products like the Vacuum Seal Drawer and Warming Drawer.

- 18 oven functions including Steam, Sous Vide, Air Fry and Vent Bake
- With steam cooking, convection cooking, or a combination of both
- Pair with our Vacuum Seal Drawer companion product for effortless Sous Vide preparation
- Easily maintain a spotless oven; Steam Clean lifts stubborn spills for quick wipe-downs

DIMENSIONS

Height	18 "
Width	29 15/16 "
Depth	22 1/4 "

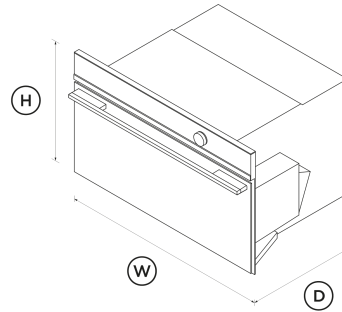

FEATURES & BENEFITS

Combination cooking

Elevate every ingredient with combination steam cooking. By blending dry convection heat with adjustable steam levels, you can preserve the delicate texture of seafood like salmon and snapper, maintain the essential vitamins and minerals in greens, and enhance the rich flavors of prime cuts of meat.

Mastery of temperature

Steam is eight times more efficient at conducting heat than convection, which means our combi steam oven can cook at reduced times and lower temperatures. It perfectly balances steam with convection heat, ensuring exceptional temperature accuracy for perfect roasting and crafting signature dishes.

Preserve flavor and nutrients

Perfect for delicate dishes like snapper or salmon, steam cooking preserves nutrients and texture, offering a healthier way to enjoy meals. With specialized steam functions, including Sous Vide, the combi steam oven brings out the best in every ingredient, ensuring your creations are both nutritious and delicious.

Complementary design

Every detail has been carefully crafted from the finest materials to enhance your kitchen's aesthetic, perfectly suiting your design style. Pair it with a Vacuum Seal Drawer for the ultimate kitchen solution.

Steam clean

Keep your oven spotless with the natural power of steam. The steam clean feature helps tackle stubborn spills, allowing for a quick wipe-down.

SPECIFICATIONS

Accessories (included)

Broil pan	1
Broil rack	1
Catalytic panels	•
Descalc solution	2
Large steam dish	1
Perforated large steam dish	1
Perforated small steam dish	1
Step down wire shelf	1
Telescopic clip-on runners	1
Wire shelf	1

Capacity

Shelf positions	4
-----------------	---

Total capacity	1.9 cu ft
Usable capacity	1.6 cu ft
Water tank capacity	47.3 L

- Smart appliance
- Soft close doors
- Touch control glass interface
- True convection oven
- Voice control
- Wireless temperature sensor compatible

- AeroTech™ technology
- Automatic rapid pre-heat
- Automatic sensor cooking
- Temperature range **95-445**

Cleaning

- Acid resistant graphite enamel
- Descalc cycle
- Drying cycle
- Easy to clean interior
- Removable oven door
- Removable shelf runners
- Removable water tank
- Steam clean (oven)

Functions

- Aero Broil
- Aero™ Bake
- Air fry
- Bake
- Maxi Broil
- Pizza bake
- Roast
- Slow cook
- Sous vide
- Steam
- Steam clean (oven)
- Steam defrost
- Steam proof
- True Aero
- True Aero + High steam
- True Aero + Low steam
- True Aero + Medium steam
- Vent bake

Power Requirements

Amperage	20 A
Supply frequency	60 Hz
Supply voltage	208 or 240 V

Controls

- Adjustable audio and display settings
- Audio feedback
- Automatic cooking/minute timer
- Automatic pre-set temperatures
- Celsius/Fahrenheit temperature
- Delay start
- Dial with illuminated halo
- Electronic capacitive touch controls
- Electronic clock
- Electronic oven control
- Food probe
- Halogen lights
- Multi-language display **true**
- Sabbath mode with Star K certification

Performance

- ActiveVent™ system

Product Dimensions

Depth	22 1/4 "
Height	18 "
Width	29 15/16 "

SKU	82643
-----	--------------

The product dimensions and specifications in this page apply to the specific product and model. Under our policy of continuous improvement, these dimensions and specifications may change at any time. You should therefore check with Fisher & Paykel's Customer Care Centre to ensure this page correctly describes the model currently available. © Fisher & Paykel Appliances Ltd 2020

Other product downloads available at fisherpaykel.com

- [↓](#) 2D-DWG Combination Steam Oven
- [↓](#) 2D-DXF Combination Steam Oven
- [↓](#) Service & Warranty

↓ Planning Guide - Contemporary 30" Built-in Ovens and Companions

Where applicable:

All appliances use energy, and energy usage typically generates carbon emissions. **Fisher & Paykel Appliances' In-use Energy Carbon Emissions Estimate** indicates carbon emissions from a product's in-use energy. This is calculated either annually or per cycle, using the product's market-specific energy label energy consumption data multiplied by the carbon emissions factor for energy in your country or region.

Our In-use Energy Carbon Emissions Estimate is designed to assist customers in making informed purchasing decisions when comparing different Fisher & Paykel products. For example, a heat pump dryer typically has a lower In-use Energy Carbon Emissions Estimate than a vented dryer.



A PEACE OF MIND SALE
24 Hours 7 Days a Week Customer Support
T 1.888.936.7872 W www.fisherpaykel.com