

Oven, 24, 11 Function, Self-cleaning

Series 9 | Contemporary

Stainless Steel



With a subtle black glass finish, this contemporary-style oven has multiple functions to ensure every dish is cooked to perfection.

- Three cubic feet total capacity with eleven oven functions including Aero™ Pastry, Roast and Rapid Proof
- Self-cleaning function breaks down food residue for an easy clean
- Moisture control and even heat distribution thanks to ActiveVent™ and AeroTech technology
- Non-tip, full-extension sliding shelves for safe removal of hot dishes

DIMENSIONS

Height	23 9/16 "
Width	23 1/2 "
Depth	22 1/4 "

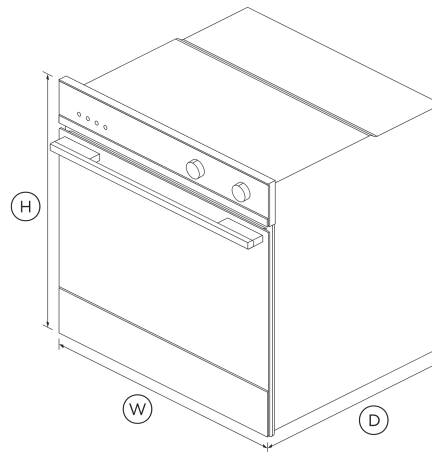

FEATURES & BENEFITS

Generous Capacity

With a generous sized internal cavity, you can create several dishes at once using multiple shelves.

Perfect Results

Our built-in ovens feature ActiveVent technology for optimized moisture levels, and AeroTech™ for even heat distribution. Get perfect results even when you're using multiple shelves.

Multi-Function Flexibility

11 functions including Aero™ Pastry, Roast and Rapid Proof mean no matter what you're cooking, you've got the right heat to match.

Seamless Fit

Designed to fit seamlessly in your kitchen, this built-in oven fits flush with cabinetry to minimize gaps and add to a cohesive aesthetic.

Refined Styling

With sophisticated handle styling and elegant black or stainless steel finish, our built-in ovens are designed to match the rest of Fisher & Paykel's kitchen appliance family.

Cleaning Is Simple

The self-clean function breaks down food residue at a very high temperature, leaving a light ash that's easily removed with a damp cloth.

Safe And Sound

The CoolTouch door features triple glazing and a cooling system that ensures it's safe to touch from the outside - protecting both your hands and the surrounding cabinetry.

SPECIFICATIONS

Accessories (included)

Step down wire shelf	1
Wired temperature sensor	1

Accessories (sold separately)

Optional Accessory round handle	Part 81671
Optional round handle	Part 81645

Capacity	
Shelf positions	6
Total capacity	3 cu ft
Usable capacity	2.5 cu ft

Cleaning	
Acid resistant graphite enamel	•
Pyrolytic self-clean	•
Removable oven door	•
Removable oven door inner glass	•
Removable shelf runners	•

Controls	
Audio feedback	•
Automatic cooking/minute timer	•
Automatic pre-set temperatures	•
Celsius/Fahrenheit temperature	•
Electronic capacitive touch controls	•
Electronic clock	•
Electronic oven control	•
Intuitive touchscreen display	•
Soft close doors	•
Turned stainless capacitive touch buttons with illuminated halos	•

Functions	
Aero Broil	•
Aero Pastry	•

Aero™ Bake	•
Bake	•
Broil	•
Maxi Broil	•
Number of functions	11
Pyrolytic self-clean	•
Rapid proof	•
Roast	•
True Aero	•
Vent bake	•
Warm	•

Performance	
ActiveVent™ system	•
AeroTech™ technology	•
Automatic rapid pre-heat	•
Broil power	3000 W
Whisper Quiet Cooking	•

Power Requirements	
Amperage	16.6-19.4 A
Supply frequency	60 Hz
Supply voltage	208-240 V

Product Dimensions	
Depth	22 1/4 "
Height	23 9/16 "
Width	23 1/2 "

Safety	
ADA compliant	•
Balanced oven door	•
Catalytic venting system	•
Control panel key lock	•
Non-tip shelves	•

SKU 82255

The product dimensions and specifications in this page apply to the specific product and model. Under our policy of continuous improvement, these dimensions and specifications may change at any time. You should therefore check with Fisher & Paykel's Customer Care Centre to ensure this page correctly describes the model currently available. © Fisher & Paykel Appliances Ltd 2020

Other product downloads available at fisherpaykel.com

- [↓](#) 2D-DWG Oven
- [↓](#) 2D-DXF Oven
- [↓](#) Data Sheet Oven
- [↓](#) Service & Warranty
- [↓](#) User Guide

Where applicable:

All appliances use energy, and energy usage typically generates carbon emissions. **Fisher & Paykel Appliances' In-use Energy Carbon Emissions Estimate** indicates carbon emissions from a product's in-use energy. This is calculated either annually or per cycle, using the product's market-specific energy label energy consumption data multiplied by the carbon emissions factor for energy in your country or region.

Our In-use Energy Carbon Emissions Estimate is designed to assist customers in making informed purchasing decisions when comparing different Fisher & Paykel products. For example, a heat pump dryer typically has a lower In-use Energy Carbon Emissions Estimate than a vented dryer.



A PEACE OF MIND SALE
24 Hours 7 Days a Week Customer Support
T 1.888.936.7872 W www.fisherpaykel.com