

90cm Series 9 Integrated CoolDrawer Multi-temperature Drawer

Series 9 | Integrated

Panel Ready



Use your CoolDrawer™ as a refrigerator, pantry or freezer with the push of a button. Customize with cabinetry or a stainless steel panel.

- Variable Temperature Zone lets you change between five different food modes – refrigerator, freezer, pantry, chill and wine
- Choose between a Professional or Contemporary stainless steel front panel and handle, or customize with your own kitchen cabinetry

DIMENSIONS

| | |
|--------|------------|
| Height | 25 3/16 " |
| Width | 33 11/16 " |
| Depth | 21 15/16 " |

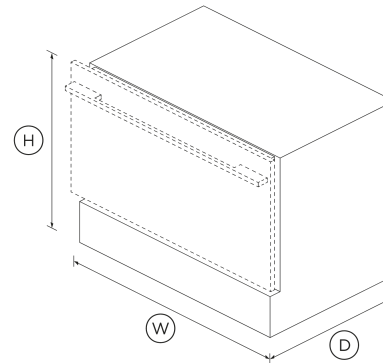

FEATURES & BENEFITS

Fridge

The ideal storage for most foods such as fruit and vegetables, dairy products, processed meats and drinks. The compact upper storage tray is a perfect place for sensitive foods such as peaches, cherries, cheeses and deli items, while the tall bin is ideal for large bottles and containers.

Pantry

Designed for foods that require a cool, dark place for storage, such as tropical fruits, tomatoes, bananas, bread and cereals. Pantry Mode provides a solution for all those foods that you didn't previously know what to do with and have always resorted to storing on the bench or in the cupboard.

Wine Mode

Using Wine Mode, connoisseurs can take advantage of special settings that preserve and present wine at its optimum temperature. Wine Mode is ideal for long term storage of all wine at 54°F. It also offers short term storage at 45°F for white wine and 59°F for red wine.

Chill Mode

Chill Mode sets the compartment to a temperature ideal for highly perishable meats, poultry and seafood. For these types of food it is ideal to hold them at a temperature as close to freezing as possible to retain their vital freshness. Chill Mode sets the compartment at 31°F, just above the freezing temperature for meat.

Freezer Mode

Ideal for general frozen food storage with the added flexibility of three freezer functions - bottle chill, fast freeze and deep freeze. Freezer Mode is set at 0°F for longer term storage for frozen items.

SPECIFICATIONS

Accessories (sold separately)

| | |
|--|-------------------|
| Door panel set stainless steel | RD3625S |
| Handle kit Classic | AHCLRD36S |
| Handle kit Contemporary round, aluminium | AHSRB36S |
| Handle kit Contemporary square fine, aluminium | AHD5RD36S |
| Handle kit Contemporary square fine, black | AHD5RD36SB |
| Handle kit Professional round flush | AHP3RD36S |

Capacity

Total gross capacity **3.1 cu ft**

Consumption

Energy rating **Energy star Most efficient**

Energy usage **150kWh/year (Refrigerator), 300kWh/year (Freezer)**

In-use energy carbon emissions estimate **55.0kgCO2e/year (Refrigerator), 110.0kgCO2e/year (Freezer)**

Features

- Door alarm •
- LED lighting •
- Rapid cool function •
- SmartTouch control panel •

Power Requirements

Supply voltage **110 V**

Product Dimensions

Depth **21 15/16 "**

Height **25 3/16 "**

Width **33 11/16 "**

Safety and compliance

ADA compliant •

Variable Temp Compartment

- Chill (mode) •
- Freezer (mode) •
- Fridge (mode) •
- Pantry •
- Wine •

Warranty

Parts and labor **2 years**

Sealed system parts & labor **additional 3 years**

SKU **25281**

The product dimensions and specifications in this page apply to the specific product and model. Under our policy of continuous improvement, these dimensions and specifications may change at any time. You should therefore check with Fisher & Paykel's Customer Care Centre to ensure this page correctly describes the model currently available. © Fisher & Paykel Appliances Ltd 2020

Other product downloads available at fisherpaykel.com

- [↓](#) 2D-DWG Integrated CoolDrawer
- [↓](#) 2D-DXF Integrated CoolDrawer
- [↓](#) Archicad Integrated CoolDrawer

- [↓](#) Data Sheet Integrated CoolDrawer
- [↓](#) Energy Label - Freezer Mode
- [↓](#) Service & Warranty
- [↓](#) Installation Guide EN
- [↓](#) Revit Integrated CoolDrawer
- [↓](#) Rhino 5
- [↓](#) Sketchup Integrated CoolDrawer
- [↓](#) Guide d'utilisation FR
- [↓](#) User Guide CoolDrawer™ EN

Where applicable:

All appliances use energy, and energy usage typically generates carbon emissions. **Fisher & Paykel Appliances' In-use Energy Carbon Emissions Estimate** indicates carbon emissions from a product's in-use energy. This is calculated either annually or per cycle, using the product's market-specific energy label energy consumption data multiplied by the carbon emissions factor for energy in your country or region.

Our In-use Energy Carbon Emissions Estimate is designed to assist customers in making informed purchasing decisions when comparing different Fisher & Paykel products. For example, a heat pump dryer typically has a lower In-use Energy Carbon Emissions Estimate than a vented dryer.



A PEACE OF MIND SALE
24 Hours 7 Days a Week Customer Support
T 1.888.936.7872 Wwww.fisherpaykel.com