

Freestanding Refrigerator Freezer, 32", 17.5 cu ft

Series 5 | Contemporary

White | Right Hinge

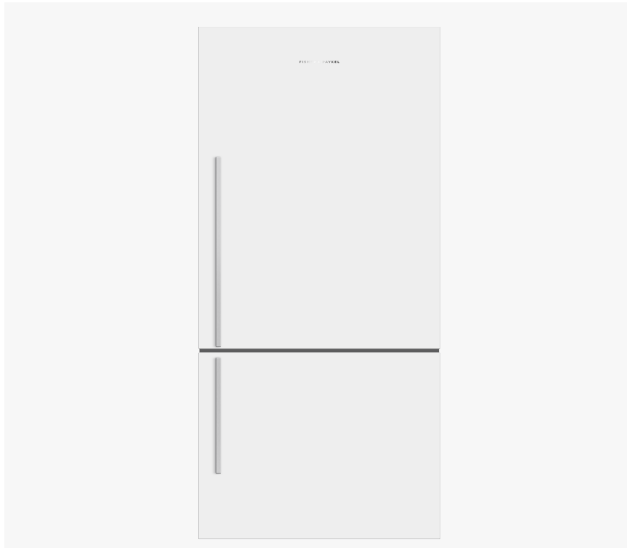

This white refrigerator with bottom freezer has large, flexible storage options for a busy household.

- Bottom freezer
- Brushed metal handles
- ActiveSmart™ helps keep food fresher for longer

DIMENSIONS

Height	67 1/2 "
Width	31 1/8 "
Depth	27 3/8 "

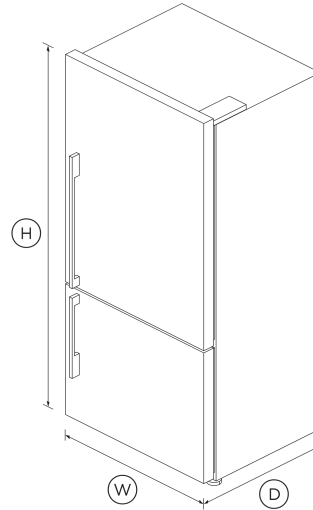

FEATURES & BENEFITS

ActiveSmart™ Foodcare

Every time you open your refrigerator, the temperature around your food changes. ActiveSmart™ foodcare adjusts airflow to create a stable temperature, helping your food stay fresher for longer.

Clever Energy

Your refrigerator adapts to daily use by cooling and defrosting only when needed. This means your refrigerator uses the energy it needs without compromising on food care.

Design Quality

Our refrigerators are designed and built using quality materials. We use pre-painted steel on our refrigerators and solid glass for shelving.

Simple Storage

This refrigerator is designed to make it simple for you to store, access and remove food. Storage bins give you full access inside when they're pulled open and can be easily removed to clean. Our flexible shelving also gives you more storage options.

Humidity Control

Your fruit and veges need different environments. The humidity control slides in each storage bin create a microclimate that helps keep food fresher for longer.

SPECIFICATIONS

Capacity

Total gross capacity	17.5 cu ft
Volume freezer	5.2 cu ft
Volume refrigerator	12.3 cu ft

Consumption

Energy rating	Energy star
Energy usage	454kWh/year
In-use energy carbon emissions estimate	166.4kgCO2e/year

Features

Adjustable door shelves	14
-------------------------	----

Adjustable glass shelves	4
Covered door shelves	2
Door alarm	•
Front levelling feet	•
Fruit and vegetable bins	2
Full extension runners	•
Full width door shelves	2
LED lighting	•
Rear rollers	•
Smart appliance	•
SmartTouch control panel	•
Spill proof removable bins	•
Stackable bottle holders	2
Wi-Fi connectivity	•

Freezer Features

Bottle chill	•
Fast freeze	•
Large plastic bins	•

Performance

ActiveSmart™ Foodcare	•
Adaptive defrost	•
Frost free	•
Frost Free Freezer	•
Humidity control system	•
Inverter controlled compressor	•
Sabbath mode	•

Product Dimensions

Depth	27 3/8 "
Height	67 1/2 "
Minimum air clearance at rear	1 3/16 "
Minimum air clearance each side	1 3/16 "
Minimum air clearance on top	2 "
Width	31 1/8 "

Variable Temp Compartment

Bottle chill mode	•
-------------------	---

Warranty

Parts and labor	2 years
Sealed system parts & labor	additional 3 years

SKU	26451
-----	-------

The product dimensions and specifications in this page apply to the specific product and model. Under our policy of continuous improvement, these dimensions and specifications may change at any time. You should therefore check with Fisher & Paykel's Customer Care Centre to ensure this page correctly describes the model currently available. © Fisher & Paykel Appliances Ltd 2020

Other product downloads available at fisherpaykel.com

- ↓ 2D-DWG Freestanding Refrigerator Freezer
- ↓ 2D-DXF Freestanding Refrigerator Freezer

- ↓ Archicad Freestanding Refrigerator Freezer
- ↓ Data Sheet Freestanding Refrigerator Freezer
- ↓ Service & Warranty
- ↓ Installation Guide
- ↓ Installation Guide - Quick Reference EN
- ↓ Guide d'installation - Instructions de Remplacement du Filtre à Eau FR
- ↓ Revit Freestanding Refrigerator Freezer
- ↓ Rhino 5
- ↓ Sketchup Freestanding Refrigerator Freezer
- ↓ User Guide
- ↓ Installation & User Guide ActiveSmart Refrigerator EN
- ↓ Energy Label

Where applicable:

All appliances use energy, and energy usage typically generates carbon emissions. **Fisher & Paykel Appliances' In-use Energy Carbon Emissions Estimate** indicates carbon emissions from a product's in-use energy. This is calculated either annually or per cycle, using the product's market-specific energy label energy consumption data multiplied by the carbon emissions factor for energy in your country or region.

Our In-use Energy Carbon Emissions Estimate is designed to assist customers in making informed purchasing decisions when comparing different Fisher & Paykel products. For example, a heat pump dryer typically has a lower In-use Energy Carbon Emissions Estimate than a vented dryer.



A PEACE OF MIND SALE
24 Hours 7 Days a Week Customer Support
 T 1.888.936.7872 W www.fisherpaykel.com