

Freestanding Range Cooker, Dual Fuel, 90cm, 5 Burners

Series 7 | Contemporary

Stainless Steel



Get the best of both worlds with dual fuel. A gas hob with wok burner is paired with a convection oven with 9 functions.

- Five burner hob with with dual wok burner and two powerful triple ring burners
- Convection oven with 140L total capacity and nine oven functions including Pastry Bake with pizza mode
- Non-tip full-extension shelves for safe removal of hot dishes

DIMENSIONS

Height	898 - 946 mm
Width	897 mm
Depth	600 mm

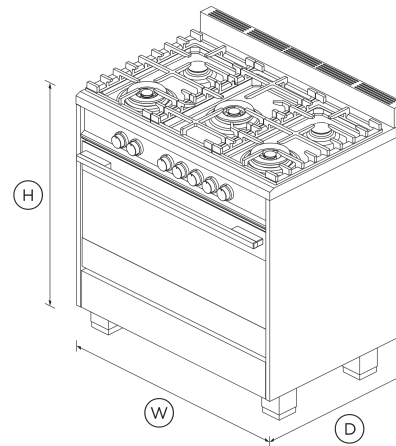

FEATURES & BENEFITS

Multi-Shelf Cooking

Our AeroTech™ system circulates air evenly throughout the entire oven so dishes on the top shelf turn out just as perfect as food cooking on the bottom shelf.

Quality And Durability

Every detail has been carefully crafted. The solid, perfectly balanced soft-close door, precise electric temperature control and chromed cast zinc dials all add up to an exceptional, premium range.

Burner Power & Control

Instant and immediate control from the highest to the gentlest heat. The finely tuned hob controls let you sear, stir fry or simmer a delicate sauce to perfection.

Easy To Clean

Cleaning up spills is effortless. Your hob simply needs a quick wipe to keep it looking good as new. The pyrolytic self-clean oven cycle breaks down food residue at a very high temperature, leaving a light ash that's easily removed with a damp cloth.

Even Heat

Accurate, electronically-controlled oven heat ensures a great result every time.

Large Capacity Oven

The generous 140L total capacity oven gives you plenty of space to cook multiple dishes at once.

SPECIFICATIONS

Accessories (included)

Chromed shelf runners	1 set
Flat wire shelf	1
Full extension sliding shelves	1 set (part 578744)
Grill rack	true
Roasting dish	1
Small pot support	1 (part 533981 cast)
Step down wire shelf	•

Accessories (sold separately)

Kick strip, stainless steel (optional)	KICKOR90X1
--	------------

Burner ratings

Dual wok burner inner/outer (LPG)	0.3 - 4.5kW
Dual wok burner inner/outer (natural gas)	0.4 - 4.5kW
Maximum burner power	4.5kW
Semi-rapid burner (LPG)	1.2kW
Semi-rapid burner (natural gas)	1.75kW
Total cooktop power	14.9kW
Triple ring wok burner (LPG) x2	4.0kW
Triple ring wok burner (natural gas) x2	4.0kW

Capacity

Shelf positions	6
Shelf positions (main oven)	6
Total capacity	140 L
Total capacity (main oven)	140 L
Usable capacity	121 L
Usable capacity (main oven)	120 L

Cleaning

Acid resistant graphite enamel	•
Drop down grill element	•
Removable oven door	•
Removable oven door inner glass	•
Removable shelf runners	•

Consumption

Energy usage	1.46kWh/cycle
--------------	----------------------

Controls

Audio feedback	•
Automatic cooking/minute timer	•
Automatic pre-set temperatures	•
Celsius/Fahrenheit temperature	•
Electronic clock	•
Laser etched graphics	•
Precise electronic temperature control	•
Sabbath mode	•
Turned stainless steel clock buttons	•
Turned stainless steel dials with illuminated halos	•

Installation Dimensions

Installation cutout dimensions (Depth)	600 mm
Installation cutout dimensions (Width)	900 mm

Oven features

AeroTech™ technology	•
Automatic rapid pre-heat	•
Electronic oven control	•
Full extension telescopic sliding shelves	•
Internal light	4 x 25W halogen (2 side & 2 top)
Soft open/close door	•
Storage drawer	•
True convection	•
Twin cavity fans	•

Oven functions

Bake	•
Classic bake	•
Energy slow cook	•
Fan bake	•
Fan forced	•
fanGrill	•
Grill	•
Number of functions	9
Pastry Bake with Pizza mode	•
Roast	•
True convection	•

Oven performance

CoolTouch door	Quadruple glazed
----------------	-------------------------

Power requirements

Amperage	22 A
Supply frequency	50 Hz

Product dimensions

Depth	600 mm
Height	898 - 946 mm
Width	897 mm

Rangetop features

Hob rear trim	60 mm
---------------	--------------

- LPG / Natural Gas compatible •
- Sealed range top •

Rangetop Performance

Number of burners **5**

Safety

- Advanced cooling system •
- Anti-tilt bracket •
- Balanced oven door •
- CoolTouch door •
- Flame failure system •
- Full extension telescopic shelves **1 set (part 578744)**
- Full extension telescopic sliding shelves •
- Non-tip shelves •
- Spill containment **26 L**

Warranty

Parts and labour **5 years**

SKU **81723**

The product dimensions and specifications in this page apply to the specific product and model. Under our policy of continuous improvement, these dimensions and specifications may change at any time. You should therefore check with Fisher & Paykel's Customer Care Centre to ensure this page correctly describes the model currently available. © Fisher & Paykel Appliances Ltd 2020



A PEACE OF MIND SALE
24 Hours 7 Days a Week Customer Support
 T 08000 886 605 Wwww.fisherpaykel.com

Other product downloads available at fisherpaykel.com

- [↓ Declaration of Conformity](#)
- [↓ Energy Label Dual Fuel Cooker](#)
- [↓ Energy Rating](#)
- [↓ Service & Warranty](#)
- [↓ Installation Guide Dual Fuel Cooker](#)
- [↓ Installation Guide - Kick Strip](#)
- [↓ Product Information Sheet](#)
- [↓ Product Fiche](#)
- [↓ Revit Freestanding Range Cooker](#)
- [↓ Rhino Freestanding Range Cooker](#)
- [↓ Sketchup Freestanding Range Cooker](#)
- [↓ User Guide Dual Fuel Cooker](#)

Where applicable:

All appliances use energy, and energy usage typically generates carbon emissions. **Fisher & Paykel Appliances' In-use Energy Carbon Emissions Estimate** indicates carbon emissions from a product's in-use energy. This is calculated either annually or per cycle, using the product's market-specific energy label energy consumption data multiplied by the carbon emissions factor for energy in your country or region.

Our In-use Energy Carbon Emissions Estimate is designed to assist customers in making informed purchasing decisions when comparing different Fisher & Paykel products. For example, a heat pump dryer typically has a lower In-use Energy Carbon Emissions Estimate than a vented dryer.