

# 20.1 cu ft Series 7 French Door Refrigerator Freezer, Ice

Series 7 | Professional

Stainless Steel | French hinge



Styled like a refrigerator found in a professional kitchen, with serious storage capacity and stylish stainless steel finish.

- ActiveSmart™ technology helps keep food fresher for longer by constantly maintaining the ideal temperature
- Internal ice maker with boost for busy times
- Spacious bottom freezer with full extension drawer gives easy access to frozen goods

## DIMENSIONS

|        |            |
|--------|------------|
| Height | 70 15/32 " |
| Width  | 35 7/16 "  |
| Depth  | 27 3/8 "   |

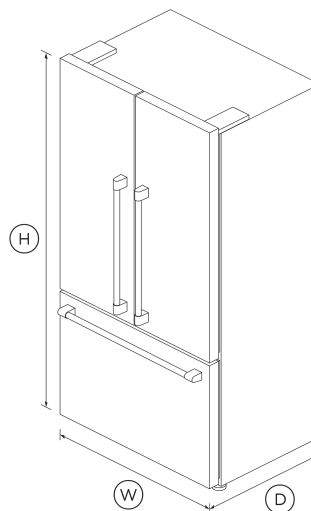

## FEATURES & BENEFITS

### Activesmart™ Foodcare

ActiveSmart™ Foodcare learns how you live. It's technology which understands how you use your refrigerator and adjusts temperature, airflow and humidity inside to help keep food fresher for longer.

### Design Quality

Our refrigerators are designed and built using quality materials. We use real stainless steel on our refrigerators, hidden hinges and solid glass for shelving.

### Clever Energy

Your refrigerator adapts to daily use by cooling and defrosting only when needed. This means your refrigerator uses the energy it needs without compromising on food care.

### Simple Storage

This refrigerator is designed to make it simple for you to store, access and remove food. Storage bins give you full access inside when they're pulled open and can be easily removed to clean. Our flexible shelving also gives you more storage options.

### Humidity Control

Your fruit and veges need different environments. The humidity control slides in each storage bin create a microclimate that helps keep food fresher for longer.

### Ice Maker

Fresh ice is always available for you in a dedicated freezer bin. Simply turn it off to free up freezer space or during busy times, you can boost ice production by up to 30%.

### Easy Cleaning

Spill-safe secure glass shelves easily capture any drips or leaks.

## SPECIFICATIONS

### Accessories (sold separately)

|                          |               |
|--------------------------|---------------|
| Water filter replacement | 847200 - FWC3 |
|--------------------------|---------------|

### Capacity

|                      |            |
|----------------------|------------|
| Total gross capacity | 20.1 cu ft |
| Volume freezer       | 5.5 cu ft  |
| Volume refrigerator  | 14.6 cu ft |

**Consumption**

|   |                         |
|---|-------------------------|
| Energy rating                           | <b>Energy star</b>      |
| Energy usage                            | <b>532kWh/year</b>      |
| In-use energy carbon emissions estimate | <b>195.0kgCO2e/year</b> |

**Features**

|                          |               |
|--------------------------|---------------|
| Adjustable door shelves  | <b>14</b>     |
| Adjustable glass shelves | <b>2</b>      |
| Covered door shelves     | <b>2</b>      |
| Deli storage bins        | <b>2</b>      |
| Door alarm               | <b>•</b>      |
| Fruit and vegetable bins | <b>2</b>      |
| LED lighting             | <b>•</b>      |
| Smart appliance          | <b>•</b>      |
| SmartTouch control panel | <b>•</b>      |
| Soft close doors         | <b>•</b>      |
| Stackable bottle holders | <b>4</b>      |
| Water Filter             | <b>836848</b> |

**Freezer Features**

|                     |          |
|---------------------|----------|
| Automatic ice maker | <b>•</b> |
| Bottle chill        | <b>•</b> |
| Door alarm          | <b>•</b> |
| Fast freeze         | <b>•</b> |
| Ice bin and scoop   | <b>•</b> |
| Ice Boost           | <b>•</b> |
| LED Lighting        | <b>•</b> |

**Performance**

|                                |          |
|--------------------------------|----------|
| ActiveSmart™ Foodcare          | <b>•</b> |
| Adaptive defrost               | <b>•</b> |
| Frost Free Freezer             | <b>•</b> |
| Humidity control system        | <b>•</b> |
| Inverter controlled compressor | <b>•</b> |
| Sabbath mode                   | <b>•</b> |

**Power Requirements**

|                  |              |
|------------------|--------------|
| Rated current    | <b>10 A</b>  |
| Supply frequency | <b>60 Hz</b> |
| Supply voltage   | <b>115 V</b> |

**Product Dimensions**

|        |                   |
|--------|-------------------|
| Depth  | <b>27 3/8 "</b>   |
| Height | <b>70 15/32 "</b> |
| Width  | <b>35 7/16 "</b>  |

**Warranty**

|                          |                |
|--------------------------|----------------|
| Parts and labor          | <b>2 years</b> |
| Sealed system parts only | <b>5 years</b> |

|     |              |
|-----|--------------|
| SKU | <b>26304</b> |
|-----|--------------|

The product dimensions and specifications in this page apply to the specific product and model. Under our policy of continuous improvement, these dimensions and specifications may change at any time. You should therefore check with Fisher & Paykel's Customer Care Centre to ensure this page correctly describes the model currently available. © Fisher & Paykel Appliances Ltd 2020

**Other product downloads available at fisherpaykel.com**

- [↓ 2D-DWG Freestanding French Door Fridge Freezer](#)
- [↓ 2D-DXF Freestanding French Door Fridge Freezer](#)
- [↓ Data Sheet Freestanding French Door Fridge Freezer](#)
- [↓ Energy Label](#)
- [↓ Service & Warranty](#)
- [↓ Installation Guide - Quick Reference EN](#)
- [↓ Installation & User Guide ActiveSmart Refrigerator EN](#)

**Where applicable:**

All appliances use energy, and energy usage typically generates carbon emissions. **Fisher & Paykel Appliances' In-use Energy Carbon Emissions Estimate** indicates carbon emissions from a product's in-use energy. This is calculated either annually or per cycle, using the product's market-specific energy label energy consumption data multiplied by the carbon emissions factor for energy in your country or region.

Our In-use Energy Carbon Emissions Estimate is designed to assist customers in making informed purchasing decisions when comparing different Fisher & Paykel products. For example, a heat pump dryer typically has a lower In-use Energy Carbon Emissions Estimate than a vented dryer.



**A PEACE OF MIND SALE**

24 Hours 7 Days a Week Customer Support

T 1.888.936.7872 W [www.fisherpaykel.com](http://www.fisherpaykel.com)