

# Freestanding Range Cooker, Dual Fuel, 90cm, 5 Burners, Self-cleaning

Series 9 | Contemporary

Stainless Steel



Get the best of both worlds with dual fuel. A gas hob with wok burner is paired with a convection oven with 9 functions.

- Five burner cooktop with dual wok burner and two powerful triple ring burners
- Convection oven with 140L total capacity and nine oven functions plus rotisserie, including Pastry Bake™ with pizza mode
- Non-tip full-extension shelves for safe removal of hot dishes

- Pyrolytic self-clean that breaks down food residue for an easy clean

## DIMENSIONS

Height	898 - 946 mm
Width	897 mm
Depth	600 mm

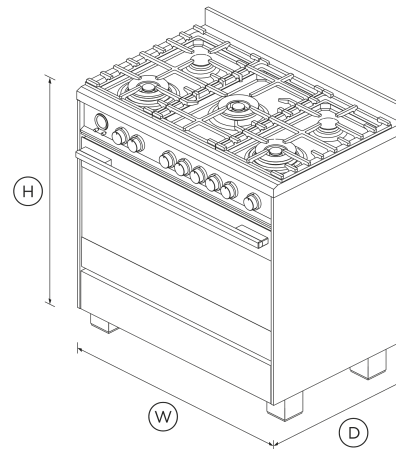

## FEATURES & BENEFITS

### Multi-Shelf Cooking

Our AeroTech™ system circulates air evenly throughout the entire oven so dishes on the top shelf turn out just as perfect as food cooking on the bottom shelf.

### Quality And Durability

Every detail has been carefully crafted. The solid, perfectly balanced soft-close door, precise electric temperature control and chromed cast zinc dials all add up to an exceptional, premium range.

### Burner Power & Control

Instant and immediate control from the highest to the gentlest heat. The finely tuned hob controls let you sear, stir fry or simmer a delicate sauce to perfection.

### Easy To Clean

Cleaning up spills is effortless. Your hob simply needs a quick wipe to keep it looking good as new. The pyrolytic self-clean oven cycle breaks down food residue at a very high temperature, leaving a light ash that's easily removed with a damp cloth.

### Even Heat

Accurate, electronically-controlled oven heat ensures a great result every time.

### Large Capacity Oven

The generous 140L total capacity oven gives you plenty of space to cook multiple dishes at once.

## SPECIFICATIONS

### Accessories (included)

Flat wire shelf	1
Full extension sliding shelves	2 sets (part 578744)
Full extension telescopic shelves	2 sets (part 578744)
Grill rack	true
Roasting dish	1
Rotisserie set	1 set

Small pot support	<b>1 (part 533981 cast)</b>
Step down wire shelf	•

**Accessories (sold separately)**

Kick strip, stainless steel (optional)	<b>KICKOR90X1</b>
--	-------------------

**Burner ratings**

Dual wok burner inner/outer (LPG)	<b>0.3 - 4.5kW</b>
Dual wok burner inner/outer (natural gas)	<b>0.4 - 4.5kW</b>
Maximum burner power	<b>4.5kW</b>
Semi-rapid burner (LPG)	<b>1.2kW</b>
Semi-rapid burner (natural gas)	<b>1.2kW</b>
Total cooktop power	<b>14.9kW</b>
Triple ring wok burner (LPG) x2	<b>4.0kW</b>
Triple ring wok burner (natural gas) x2	<b>4.0kW</b>

**Capacity**

Shelf positions (main oven)	<b>6</b>
Total capacity	<b>140 L</b>
Usable capacity (main oven)	<b>120 L</b>

**Cleaning**

Acid resistant graphite enamel	•
Drop down grill element	•
Pyrolytic proof shelf runners	•
Pyrolytic self-clean	•
Removable oven door	•

Removable oven door inner glass	•
Removable shelf runners	•

**Consumption**

Energy usage	<b>1.62kWh/cycle</b>
--------------	----------------------

**Controls**

Audio feedback	•
Automatic cooking/minute timer	•
Automatic pre-set temperatures	•
Celsius/Fahrenheit temperature	•
Electronic clock	•
High resolution display	•
Laser etched graphics	•
Precise electronic temperature control	•
Sabbath mode	•
Turned stainless steel clock buttons	•
Turned stainless steel clock crown (dial)	•
Turned stainless steel dials with illuminated halos	•

**Installation Dimensions**

Installation cutout dimensions (Depth)	<b>600 mm</b>
Installation cutout dimensions (Width)	<b>900 mm</b>

**Oven features**

AeroTech™ technology	•
Automatic rapid pre-heat	•

Electronic oven control	•
Full extension telescopic sliding shelves	•
Internal light	<b>4 x 25W halogen (2 side &amp; 2 top)</b>
Soft open/close door	•
True convection	•
Twin cavity fans	•
Warming drawer	•

**Oven functions**

Bake	•
Energy slow cook	•
Fan bake	•
Fan forced	•
fanGrill	•
Grill	•
Number of functions	<b>9</b>
Pastry Bake with Pizza mode	•
Roast	•
Rotisserie	•
True convection	•

**Oven performance**

CoolTouch door	<b>Quadruple glazed</b>
Warming drawer power	<b>202 W</b>

**Power requirements**

Amperage	<b>23 A</b>
Supply frequency	<b>50 Hz</b>

**Product details**Self Cleaning Sf **Yes****Product dimensions**Depth **600 mm**Height **898 - 946 mm**Width **897 mm****Rangetop features**

Brass burner spreader (power burner) •

Embossed brass burner cap (power burner) •

Hob rear trim **60 mm**

LPG / Natural Gas compatible •

Sealed range top •

**Safety**

Advanced cooling system •

Anti-tilt bracket •

Balanced oven door •

Catalytic venting system •

CoolTouch door •

Flame failure system •

Full extension telescopic sliding shelves •

Non-tip shelves •

Spill containment **26 L****Warranty**Parts and labour **5 years**SKU **81698**

The product dimensions and specifications in this page apply to the specific product and model. Under our policy of continuous improvement, these dimensions and specifications may change at any time. You should therefore check with Fisher & Paykel's Customer Care Centre to ensure this page correctly describes the model currently available. © Fisher & Paykel Appliances Ltd 2020

**Other product downloads available at fisherpaykel.com**

- [↓ Declaration of Conformity](#)
- [↓ Energy Label Dual Fuel Cooker](#)
- [↓ Energy Rating](#)
- [↓ Service & Warranty](#)
- [↓ Installation Guide](#)
- [↓ Installation Guide - Kick Strip](#)
- [↓ Product Information Sheet](#)
- [↓ Product Fiche](#)
- [↓ Revit Dual Fuel Cooker](#)
- [↓ Rhino Dual Fuel Cooker](#)
- [↓ Sketchup Dual Fuel Cooker](#)
- [↓ User Guide Dual Fuel Cooker](#)

**Where applicable:**

All appliances use energy, and energy usage typically generates carbon emissions. **Fisher & Paykel Appliances' In-use Energy Carbon Emissions Estimate** indicates carbon emissions from a product's in-use energy. This is calculated either annually or per cycle, using the product's market-specific energy label energy consumption data multiplied by the carbon emissions factor for energy in your country or region.

Our In-use Energy Carbon Emissions Estimate is designed to assist customers in making informed purchasing decisions when comparing different Fisher & Paykel products. For example, a heat pump dryer typically has a lower In-use Energy Carbon Emissions Estimate than a vented dryer.



**A PEACE OF MIND SALE**  
24 Hours 7 Days a Week Customer Support

T 08000 886 605 W [www.fisherpaykel.com](http://www.fisherpaykel.com)