

# Oven, 30, 17 Function, Self-cleaning

Series 9 | Minimal

Black



With elegant minimal styling, advanced cook functions and touchscreen, this large built-in oven is a highlight of our collection.

- Guided cooking using your touchscreen makes it simple to cook by food, function or recipe.
- 4.1 cu ft total capacity, with 17 oven functions including Aero™ Pastry and Roast, Air Fry and Dehydrate
- Non-tip, full extension sliding shelves for safe removal of hot dishes
- Accessories include food probe, smokeless grill tray, and more

## DIMENSIONS

Height	27 3/16 "
Width	29 15/16 "
Depth	23 15/16 "

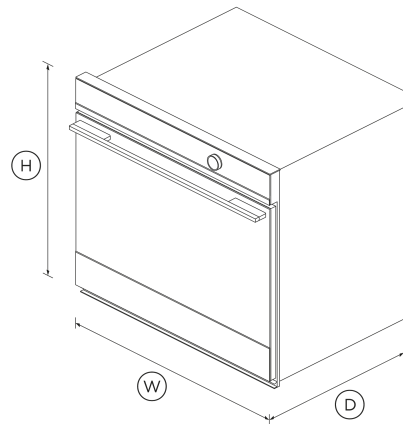

## FEATURES & BENEFITS

### Cook With Confidence

Our touchscreen interface provides an intuitive guided cooking experience that helps deliver perfect results, whether you've been cooking all your life or just starting out. Cook with a favorite method, a hero ingredient, or a go-to cooking function or recipe.

### Generous Capacity

With its 4.1 cu ft total capacity, you can create several perfectly cooked dishes at once using multiple shelves.

### Multi-Function Flexibility

The cooking functions have each been tailored, tested, tweaked and perfected to ensure that no matter what you're cooking, you've got the right heat to match. Purchase our Wireless Temperature Sensor accessory and precisely monitor cooking in real time (accessory sold separately).

### Exceptional Performance

AeroTech circulates heat evenly for a consistent temperature throughout the cavity, helping you ensure perfect results even when cooking on multiple shelves.

### Self-Cleaning

Our self-clean technology breaks down food residue at a very high temperature, leaving a light ash that's easily removed with a damp cloth. The enamel coated side racks don't need to be removed when using this function.

### Design Freedom

Available in an elegant black or a stylish black with stainless steel, this oven is designed to fit seamlessly into your kitchen. Premium materials and detailing to support a cohesive, considered kitchen design.

## SPECIFICATIONS

### Accessories (included)

Full extension sliding shelves	3 sets
Grill rack	1 set
Roasting dish	1
Smokeless grill tray	1
Wired temperature sensor	1

### Capacity

Shelf positions	8
-----------------	---

Total capacity	<b>4.1 cu ft</b>
Usable capacity	<b>3.6 cu ft</b>

**Cleaning**

Acid resistant graphite enamel	•
Removable oven door	•
Removable shelf runners	•

**Controls**

Adjustable audio and display settings	•
Automatic cooking/minute timer	•
Automatic pre-set temperatures	•
Celsius/Fahrenheit temperature	•
Electronic clock	•
Electronic oven control	•
Food probe	•
Guided cooking by food type and recipes	•
Intuitive touchscreen display	•
Multi-language display	<b>UK English, US English, Simplified Chinese, Français, Español</b>
Sabbath mode with Star K certification	•
Smart appliance	•
Wi-Fi connectivity	•

**Functions**

Aero Broil	•
Aero™ Bake	•

Air fry	•
Bake	•
Broil	•
Classic bake	•
Dehydrate	•
Maxi Broil	•
Number of functions	<b>17</b>
Pastry Bake	•
Pizza bake	•
Pyrolytic self-clean	•
Rapid proof	•
Roast	•
Slow cook	•
True Aero	•
Vent bake	•
Warm	•

**Performance**

AeroTech™ technology	•
Automatic rapid pre-heat	•
Broil power	<b>4400 W</b>
Broil width	<b>20 mm</b>
Broil width	<b>20 "</b>
Number of passes on broil	<b>10</b>
Number of passes on Maxi Broil	<b>12</b>

**Power Requirements**

Amperage	<b>16.6 - 19.4 A</b>
Supply voltage	<b>208 / 240 V</b>

**Product Dimensions**

Depth	<b>23 15/16 "</b>
Height	<b>27 3/16 "</b>
Width	<b>29 15/16 "</b>

**Safety**

ADA compliant	•
Balanced oven door	•
Catalytic venting system	•
Control panel key lock	•
CoolTouch door	•
Non-tip shelves	•

SKU	81862
-----	-------

The product dimensions and specifications in this page apply to the specific product and model. Under our policy of continuous improvement, these dimensions and specifications may change at any time. You should therefore check with Fisher & Paykel's Customer Care Centre to ensure this page correctly describes the model currently available. © Fisher & Paykel Appliances Ltd 2020

**Other product downloads available at [fisherpaykel.com](https://fisherpaykel.com)**

- [↓](#) 2D-DWG Oven
- [↓](#) 2D-DXF Oven
- [↓](#) Service & Warranty
- [↓](#) Installation Guide EN / Guide d'installation FR
- [↓](#) Installation Guide
- [↓](#) Planning Guide - Minimal 30" Built-in Ovens and Companions

- ↓ Revit Oven
- ↓ Rhino Oven
- ↓ Sketchup Oven
- ↓ User Guide

**Where applicable:**

All appliances use energy, and energy usage typically generates carbon emissions. **Fisher & Paykel Appliances' In-use Energy Carbon Emissions Estimate** indicates carbon emissions from a product's in-use energy. This is calculated either annually or per cycle, using the product's market-specific energy label energy consumption data multiplied by the carbon emissions factor for energy in your country or region.

Our In-use Energy Carbon Emissions Estimate is designed to assist customers in making informed purchasing decisions when comparing different Fisher & Paykel products. For example, a heat pump dryer typically has a lower In-use Energy Carbon Emissions Estimate than a vented dryer.



**A PEACE OF MIND SALE**  
**24 Hours 7 Days a Week Customer Support**  
T 1.888.936.7872 W [www.fisherpaykel.com](http://www.fisherpaykel.com)