

# Freestanding Cooker, Dual Fuel, 90cm, 5 Burners

Series 7 | Classic

Stainless Steel



Get the best of both worlds with dual fuel. A gas cooktop with wok burner is paired with a nine-function convection oven.

- Five burner gas cooktop, with precise heat control
- Convection oven with 140L total capacity and nine oven functions including Pastry Bake and Rapid Proof
- Non-tip full-extension shelves for safe removal of hot dishes

## DIMENSIONS

Height	898 - 946 mm
Width	897 mm
Depth	600 mm

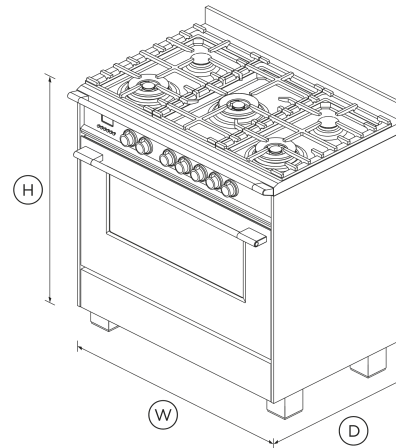

## FEATURES & BENEFITS

### Multi-Shelf Cooking

Our AeroTech™ system circulates air evenly throughout the entire oven so dishes on the top shelf turn out just as perfectly as food cooking on the bottom shelf.

### Quality And Durability

Every detail has been carefully crafted. The solid, perfectly balanced soft-close door and durable cooktop trivets all add up to an exceptional, premium range.

### Burner Power & Control

Instant and immediate control from the highest to the gentlest heat. The finely tuned cooktop controls let you sear, stir fry or simmer a delicate sauce to perfection.

### Large Capacity Oven

The generous 140L total capacity oven gives you plenty of space to cook multiple dishes at once.

### Easy To Clean

Your cooktop simply needs a quick wipe to keep it looking good as new for years to come, as the gas cooktop is made from a single piece of stainless steel that contains spills. The oven door, its inner pane of glass and runners can also be removed for easy cleaning.

### Even Heat

Accurate, electronically-controlled oven heat ensures a great result every time.

## SPECIFICATIONS

### Accessories (included)

Chromed shelf runners	1 set
Flat wire shelf	1
Roasting dish	1
Small pot support	1 (part 533981 cast)
Step down wire shelf	•

### Accessories (sold separately)

Full extension sliding shelves	Optional (part 578744)
Full extension telescopic shelves	Optional (part 578744)
Kick strip, stainless steel (optional)	KICKOR90X1

**Burner ratings**

Dual wok burner inner/outer (LPG)	<b>14.9MJ/h</b>
Dual wok burner inner/outer (natural gas)	<b>16.2MJ/h</b>
Maximum burner power	<b>16.2MJ/h</b>
Semi-rapid burner (natural gas)	<b>5.8MJ/h</b>
Semi-rapid burner (natural gas) x2	<b>6.5MJ/h</b>
Total cooktop power	<b>58.0MJ/h</b>
Triple ring wok burner (LPG) x2	<b>14.4MJ/h</b>
Triple ring wok burner (natural gas) x2	<b>14.4MJ/h</b>

**Capacity**

Shelf positions	<b>6</b>
Shelf positions (main oven)	<b>6</b>
Total capacity	<b>140 L</b>
Usable capacity	<b>121 L</b>
Usable capacity (main oven)	<b>121 L</b>

**Cleaning**

Acid resistant graphite enamel	•
Drop down grill element	•
Removable oven door	•
Removable oven door inner glass	•
Removable shelf runners	•

**Controls**

Audio feedback	•
Automatic cooking/minute timer	•
Automatic pre-set temperatures	•

Celsius/Fahrenheit temperature	•
Electronic clock	•
Laser etched graphics	•
Precise electronic temperature control	•
Sabbath mode	•
Turned stainless steel clock buttons	•

**Installation Dimensions**

Installation cutout dimensions (Depth)	<b>600 mm</b>
Installation cutout dimensions (Width)	<b>900 mm</b>

**Oven features**

AeroTech™ technology	•
Automatic rapid pre-heat	•
Bright chromed, cast zinc dials with illuminated halos	•
Electronic oven control	•
Full extension telescopic sliding shelves	•
Internal light	<b>4 x 25W halogen (2 side &amp; 2 top)</b>
Storage compartment	•
True convection	•
Twin cavity fans	•

**Oven functions**

Bake	•
Classic bake	•
Fan bake	•
Fan forced	•

Fan grill	•
Grill	•
Number of functions	<b>9</b>
Pastry Bake with Pizza mode	•
Rapid proof	•
Roast	•
True convection	•

**Oven performance**

CoolTouch door	<b>Triple glazed</b>
----------------	----------------------

**Power requirements**

Amperage	<b>22 A</b>
Supply frequency	<b>50 Hz</b>
Supply voltage	<b>220 - 240 V</b>

**Product dimensions**

Depth	<b>600 mm</b>
Height	<b>898 - 946 mm</b>
Width	<b>897 mm</b>

**Rangetop features**

Hob rail	•
Hob rear trim	<b>60 mm</b>
LPG / Natural Gas compatible	•
Sealed range top	•

**Rangetop Performance**

Number of burners **5**

---

**Safety**

Advanced cooling system •  
Anti-tilt bracket •  
Balanced oven door •  
CoolTouch door •  
Flame failure system •  
Full extension telescopic shelves **Optional (part 578744)**  
Non-tip shelves •  
Spill containment **26 L**

---

**Warranty**

Parts and labour **2 years**

---

SKU **81680**

---

The product dimensions and specifications in this page apply to the specific product and model. Under our policy of continuous improvement, these dimensions and specifications may change at any time. You should therefore check with Fisher & Paykel's Customer Care Centre to ensure this page correctly describes the model currently available. © Fisher & Paykel Appliances Ltd 2020

Other product downloads available at [fisherpaykel.com](https://fisherpaykel.com)



## Service & Warranty

- [↓ Installation Guide](#)
- [↓ Installation Guide - Kick Strip](#)
- [↓ Revit Dual Fuel Cooker](#)
- [↓ Rhino Dual Fuel Cooker](#)
- [↓ Sketchup Dual Fuel Cooker](#)
- [↓ User Guide](#)

### Where applicable:

All appliances use energy, and energy usage typically generates carbon emissions. **Fisher & Paykel Appliances' In-use Energy Carbon Emissions Estimate** indicates carbon emissions from a product's in-use energy. This is calculated either annually or per cycle, using the product's market-specific energy label energy consumption data multiplied by the carbon emissions factor for energy in your country or region.

Our In-use Energy Carbon Emissions Estimate is designed to assist customers in making informed purchasing decisions when comparing different Fisher & Paykel products. For example, a heat pump dryer typically has a lower In-use Energy Carbon Emissions Estimate than a vented dryer.



**A PEACE OF MIND SALE**  
24 Hours 7 Days a Week Customer Support  
T 0800 372 273 W [www.fisherpaykel.com](http://www.fisherpaykel.com)