

Oven, 24", 16 Function, Self-cleaning

Series 7 | Contemporary

Stainless Steel



With beautiful Contemporary styling and a generous 85L total capacity capacity, this built-in oven helps to ensures that every dish you create is cooked to perfection.

- 3 cu ft total capacity, with 16 oven functions including Air Fry and Dehydrate
- Moisture level control with ActiveVent technology
- Pyrolytic self-cleaning function breaks down food residue for an easy clean

- Guided cooking capability offers helpful tips for different food types

DIMENSIONS

Height	23 9/16 "
Width	23 7/16 "
Depth	22 1/4 "

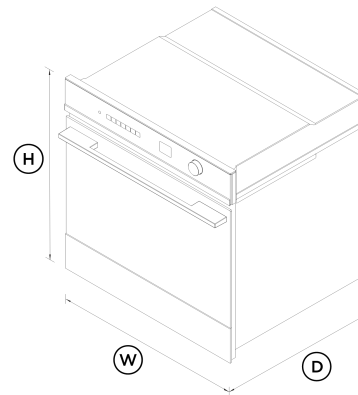

FEATURES & BENEFITS

Multi-Function Flexibility

Each function has been perfected to ensure that no matter what you're cooking, you've got the right heat to match. This built-in oven has 16 functions including Pastry Bake, Roast, Fan Grill, Dehydrate and Rapid Proof, allowing you to use a variety of cooking styles.

Generous Capacity

With a generous 3 cu ft total capacity, you can create several perfectly cooked dishes at once using multiple shelves.

Cook With Confidence

The intuitive 2.4" screen provides an intuitive guided cooking experience that helps to deliver perfect results, whether you've been cooking all your life or are just starting out. Cook by food type and allow your oven to guide you through steps, or change temperature and heat type automatically, depending on your selection.

Exceptional performance

Our unique cooking technologies were developed to deliver perfect results. ActiveVent ensures optimised moisture levels, while AeroTech™ circulates heat evenly for a consistent temperature.

Self-Cleaning

Pyrolytic self-clean breaks down food residue at a very high temperature, leaving a light ash that's easily removed with a damp cloth. The enamel coated side racks don't need to be removed when using this function.

Design Freedom

Designed to fit seamlessly into your kitchen, this built-in oven features premium materials and detailing to support a cohesive, considered kitchen design.

Safe And Sound

The CoolTouch door features triple glazing and a cooling system that ensures it's safe to touch from the outside - protecting both your hands and the surrounding cabinetry.

SPECIFICATIONS

Accessories (included)

Broil pan

1

Broil rack	1
Full extension sliding shelves	1 set
Pyrolytic proof shelf runners	•
Step down wire shelf	1
Wired temperature sensor	1

Capacity

Shelf positions	6
Total capacity	3 cu ft
Usable capacity	2.5 cu ft

Cleaning

Acid resistant graphite enamel	•
Pyrolytic proof shelf runners	•
Pyrolytic self-clean	•
Removable oven door	•
Removable oven door inner glass	•
Removable shelf runners	•

Consumption

Energy usage	271kWh/year
In-use energy carbon emissions estimate	33.4kgCO2e/year

Controls

Adjustable audio and display settings	•
Automatic cooking/minute timer	•
Automatic pre-set temperatures	•

Celsius/Fahrenheit temperature	•
Delay start	•
Electronic clock	•
Electronic oven control	•
Food probe	•
Halogen lights	•
Sabbath mode with Star K certification	•
Soft close doors	•
True convection oven	•
Turned stainless steel dials with illuminated halos	•
Wi-Fi connectivity	•

Functions

Aero Broil	•
Aero™ Bake	•
Air fry	•
Bake	•
Broil	•
Classic bake	•
Dehydrate	•
Number of functions	16
Pastry Bake	•
Pizza bake	•
Pyrolytic self-clean	•
Rapid proof	•
Roast	•
Slow cook	•
True Aero	•
Vent bake	•
Warm	•

Performance

ActiveVent™ system	•
AeroTech™ technology	•
Automatic rapid pre-heat	•
Temperature range	95°F - 540°F
Whisper Quiet Cooking	•

Power requirements

Amperage	16.6 - 19.4 A
Supply frequency	60 Hz
Supply voltage	208-240 V

Product dimensions

Depth	22 1/4 "
Height	23 9/16 "
Width	23 7/16 "

Safety

Balanced oven door	•
Catalytic venting system	•
Control panel key lock	•
CoolTouch door	•
Non-tip shelves	•
Safety thermostat	•

Warranty

Parts and labor	2 years
-----------------	---------

SKU

82558

The product dimensions and specifications in this page apply to the specific product and model. Under our policy of continuous improvement, these dimensions and specifications may change at any time. You should therefore check with Fisher & Paykel's Customer Care Centre to ensure this page correctly describes the model currently available. © Fisher & Paykel Appliances Ltd 2020

Other product downloads available at fisherpaykel.com

- [↓](#) 2D-DWG Oven
- [↓](#) 2D-DXF Oven
- [↓](#) ArchiCAD Oven
- [↓](#) Datasheet Oven
- [↓](#) Energy Label
- [↓](#) Service & Warranty
- [↓](#) Installation Guide Wall Oven EN
- [↓](#) Guide d'installation FR
- [↓](#) Guía de instalación SP
- [↓](#) Preliminary Specification Guide Wall Oven
- [↓](#) Revit Oven
- [↓](#) Rhino Oven
- [↓](#) SketchUp Oven
- [↓](#) User Guide Oven EN
- [↓](#) Guide d'utilisation FR
- [↓](#) Guía del usuario ES

Where applicable:

All appliances use energy, and energy usage typically generates carbon emissions. **Fisher & Paykel Appliances' In-use Energy Carbon Emissions Estimate** indicates carbon emissions from a product's in-use energy. This is calculated either annually or per cycle, using the product's market-specific energy label energy consumption data multiplied by the carbon emissions factor for energy in your country or region.

Our In-use Energy Carbon Emissions Estimate is designed to assist customers in making informed purchasing decisions when comparing different Fisher & Paykel products. For example, a heat pump dryer typically has a lower In-use Energy Carbon Emissions Estimate than a vented dryer.

**A PEACE OF MIND SALE****24 Hours 7 Days a Week Customer Support**T 1.888.936.7872 W www.fisherpaykel.com