

Series 5, Integrated Dishwasher

Series 5 | Integrated

Panel Ready



Offering a superior wash performance, this Dishwasher is panel ready and designed to be integrated into your kitchen for a seamless look.

- Customize with your own front panel and handle to match your kitchen cabinetry
- Seven wash programs to suit any load, from Delicate to Heavy
- Quick, Sanitize and Extra Dry provide extra wash options

- Flexible racking allows you to customise internal shelves to suit your needs

DIMENSIONS

Height	32 5/16 - 36 1/2 "
Width	23 3/4 "
Depth	22 3/4 "

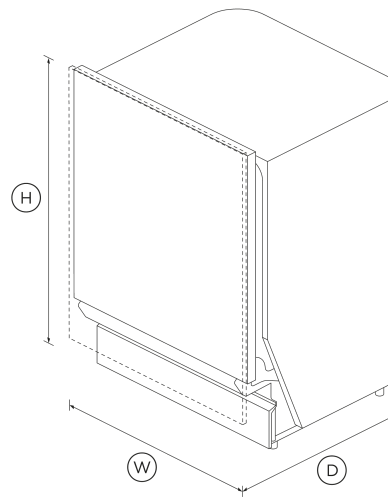

FEATURES & BENEFITS

Sized To Suit

Install this fully integrated dishwasher to tall (American size) or short (Euro/ADA size) counter heights, ensuring minimal gaps. Customize with a front panel to match kitchen cabinetry.

A Quality Wash

This dishwasher offers seven wash programs including Auto, which automatically senses the optimal wash cycle for your dishes. The three stage filtration system delivers a superior clean, while the rinse aid indicator reminds you to top up for squeaky-clean dishes.

Flexible Stacking

Designed to fit 14 place settings, the flexible, adjustable storage lets you stack even large items with ease - featuring a full width cutlery tray, height adjustable middle rack, cup holders and wine glass supports.

Quick, Sanitize And Extra Dry Options

A Quick wash modifier results in a faster clean, while maintaining wash performance. The Sanitize option provides extra protection killing 99.9% of bacteria in the final rinse. The Extra Dry setting is perfect for plastic dishes.

Quiet And Reliable

Running at a very low decibel rating, this dishwasher does its job without making a fuss. The combination of clever technology and simple mechanics means greater reliability and superior wash performance.

Efficient Performance

This dishwasher is very efficient in its use of water and energy, while delivering a powerful wash that ensures optimal results.

SPECIFICATIONS

Accessories (included)

Kickstrip true

Accessories (sold separately)

Door panel stainless steel AD-DW ADA
 Handle kit Classic AHCL-DDDW-24X

Handle kit Contemporary round, aluminium	AHS-OBDD-60S
Handle kit Contemporary square fine, aluminium	AHD5-OBDD-60SX
Handle kit Contemporary square fine, black	AHD5-OBDD-60SB
Handle kit Contemporary square, aluminium	AHD3-OBDD-60S
Handle kit Professional round flush	AHP3-DWDD-SX
Handle kit Professional round flush, Brass off-stands	AHP3DDD24BA
Handle kit Professional round flush, Dark Copper off-stands	AHP3DDD24DC

- Energy saving delay start option of up to 12 hours
- Floor light cycle feedback
- Keylock
- Rinse aid indicator light

Warranty	
Parts and labor	2 years

Features

- Quiet operation
- ThermoDry system
- Three-stage filtration system
- Variable wash pressure technology

Wash Program Modifiers

Extra Dry	•
Half load	•
Quick	•
Sanitise	•
Wash modifiers	4

Capacity and loading

Accommodates round plates up to	10 1/4"
Fold down tines	•
Full width cutlery/utensil tray	•
Height adjustable rear wine glass supports	•
Pitch adjustable tines	•
Place settings	14
Place settings	14
Wine glass supports	•

Performance

Noise emissions	46 dBA
-----------------	---------------

Power requirements

Amperage	10A
Supply frequency	50Hz
Supply voltage	220 - 240V

Wash Programs

Auto	•
Delicate	•
Eco	•
Fast	•
Heavy	•
Medium	•
Rinse	•
Wash programs	7

Consumption

Energy rating	Energy star
Energy usage	232kWh/year
In-use energy carbon emissions estimate	28.6kgCO2e/year
Water usage (per wash cycle)	3 gal

Product dimensions

Depth	22 3/4 "
Height	32 5/16 - 36 1/2 "
Width	23 3/4 "

Water connection

Water pressure	100kPa - 1000kPa
----------------	-------------------------

Controls

End of cycle beeps	•
--------------------	---

Safety and compliance

ADA compliant	•
---------------	---

SKU	81872
-----	-------

The product dimensions and specifications in this page apply to the specific product and model. Under our policy of continuous improvement, these dimensions and specifications may change at any time. You should therefore check with Fisher & Paykel's Customer Care Centre to ensure this page correctly describes the model currently available. © Fisher & Paykel Appliances Ltd 2020



A PEACE OF MIND SALE
24 Hours 7 Days a Week Customer Support
T 1.888.936.7872 W www.fisherpaykel.com

Other product downloads available at fisherpaykel.com

- [↓](#) 2D-DWG Integrated Dishwasher
- [↓](#) 2D-DXF Integrated Dishwasher
- [↓](#) Energy Label
- [↓](#) Energy Label Integrated Dishwasher
- [↓](#) Service & Warranty
- [↓](#) Installation Guide EN
- [↓](#) Guide d'installation FR
- [↓](#) Planning Guide Professional Style Dial/Handle Accessories
- [↓](#) Quick Start Guide
- [↓](#) Guide De Démarrage Rapide FR
- [↓](#) User Guide
- [↓](#) Guide d'utilisation FR

Where applicable:

All appliances use energy, and energy usage typically generates carbon emissions. **Fisher & Paykel Appliances' In-use Energy Carbon Emissions Estimate** indicates carbon emissions from a product's in-use energy. This is calculated either annually or per cycle, using the product's market-specific energy label energy consumption data multiplied by the carbon emissions factor for energy in your country or region.

Our In-use Energy Carbon Emissions Estimate is designed to assist customers in making informed purchasing decisions when comparing different Fisher & Paykel products. For example, a heat pump dryer typically has a lower In-use Energy Carbon Emissions Estimate than a vented dryer.