

76cm Series 9 Professional Compact Combi-Microwave Oven

Series 9 | Professional

Stainless Steel

The speed of microwave cooking with the versatility of convection oven technology, designed for perfect pairing with other companion products such as a steam oven or warming drawer.

- Generous 49L capacity, with four shelf positions
- With four microwave-only functions, 14 traditional oven functions, and four combination functions
- Guided touchscreen cooking makes it simple to navigate cooking processes
- Wi-Fi enabled and works with the SmartHQ™ app for remote control and notifications

DIMENSIONS

Height	458 mm
Width	757 mm
Depth	575 mm

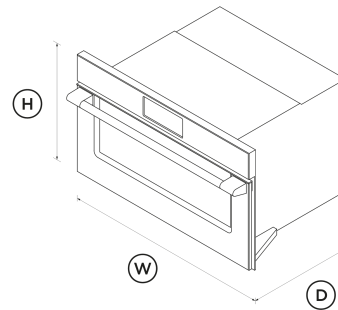

FEATURES & BENEFITS

Cooking flexibility

Choose from 22 functions, including four microwave-only functions, 14 traditional oven functions, and four combination functions, giving you the best microwave and convection oven technology.

Cook with confidence

The large touchscreen provides an intuitive guided cooking experience that helps to deliver perfect results, whether you've been cooking all your life or are just starting out.

Sized to suit

As a companion product this microwave oven is designed to be placed almost anywhere - fitting perfectly with a steam oven or other companion products to create a suite of kitchen appliances at your fingertips, and for your convenience.

Easy to use

The intuitive touch display shows you all the information you need, allowing you to easily program in your desired cooking mode and duration.

Multi-function flexibility

Each function has been tailored and tested to ensure perfect defrosting, heating and cooking. Use the included Wired Temperature Sensor to precisely monitor cooking in real time.

Safe and sound

The CoolTouch door is safe to touch from the outside, protecting your hands and the surrounding cabinetry.

SPECIFICATIONS

Accessories (included)

Chromed shelf runners	•
Glass tray	1
Grill rack	1 set
Step down wire shelf	1
Wire shelf	1
Wired temperature sensor	1

Capacity

Shelf positions	4
Total capacity	49 L
Usable capacity	38 L

Cleaning

Acid resistant graphite enamel	•
Drying cycle	•
Easy to clean interior	•

Removable shelf runners •

Controls

- Adjustable audio and display settings •
- Audio feedback •
- Automatic cooking/minute timer •
- Automatic pre-set temperatures •
- Celsius/Fahrenheit temperature •
- Certified Sabbath mode •
- Delay start •
- Dial with illuminated halo •
- Electronic capacitive touch controls •
- Electronic clock •
- Electronic oven control •
- Food probe •
- Guided cooking by food type and recipes •
- Halogen lights •
- Intuitive touchscreen display •
- Microwave timer •
- Multi-language display **true**
- Push-to-open drawer •
- Smart appliance •
- Soft close doors •
- Touch control glass interface •
- True convection oven •
- Turned stainless steel dials with illuminated halos •

- Bake •
- Defrost •
- Dehydrate •
- Fan bake •
- Fan forced •
- Fan forced + Micro •
- Fan grill •
- Fan grill + Micro (2 levels) •
- Grill •
- Grill + Micro (2 levels) •
- Microwave cooking •
- Pastry Bake •
- Pizza bake •
- Popcorn •
- Quick start •
- Rapid proof •
- Roast •
- Roast + Micro (2 levels) •
- Slow cook •
- Vent bake •
- Warm •

Performance

- ActiveVent™ system •
- AeroTech™ technology •
- Automatic sensor cooking •

Power requirements

Amperage **16 A**

Supply frequency **50 Hz**

Supply voltage **220 - 240 V**

Product dimensions

Depth **575 mm**

Height **458 mm**

Width **757 mm**

SKU **82678**

The product dimensions and specifications in this page apply to the specific product and model. Under our policy of continuous improvement, these dimensions and specifications may change at any time. You should therefore check with Fisher & Paykel's Customer Care Centre to ensure this page correctly describes the model currently available. © Fisher & Paykel Appliances Ltd 2020

Other product downloads available at fisherpaykel.com

- [↓](#) 2D-DWG Combination Microwave Oven
- [↓](#) 2D-DXF Combination Microwave Oven
- [↓](#) Service & Warranty
- [↓](#) Planning Guide - 76cm Built-in Ovens and Companions - Professional

Where applicable:

Functions

- Air fry •

All appliances use energy, and energy usage typically generates carbon emissions. **Fisher & Paykel Appliances' In-use Energy Carbon Emissions Estimate** indicates carbon emissions from a product's in-use energy. This is calculated either annually or per cycle, using the product's market-specific energy label energy consumption data multiplied by the carbon emissions factor for energy in your country or region.

Our In-use Energy Carbon Emissions Estimate is designed to assist customers in making informed purchasing decisions when comparing different Fisher & Paykel products. For example, a heat pump dryer typically has a lower In-use Energy Carbon Emissions Estimate than a vented dryer.



A PEACE OF MIND SALE
24 Hours 7 Days a Week Customer Support
T 0800 372 273 W www.fisherpaykel.com