

# Wall Range Hood, 24", Box Chimney

Series 7 | Contemporary

Stainless Steel and Glass

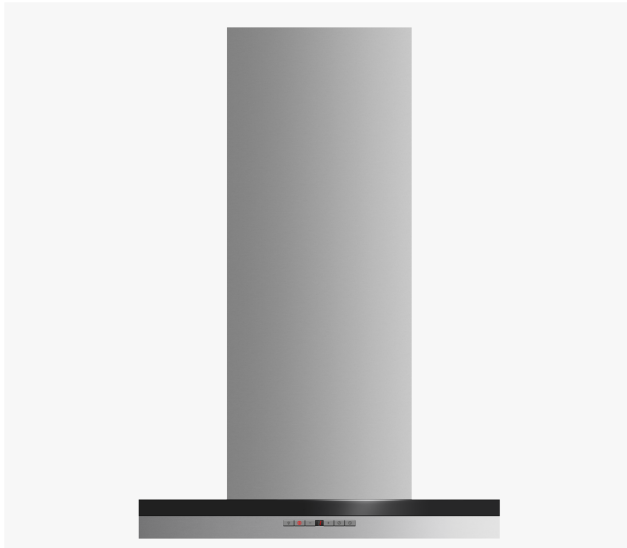

The wall chimney range hood has contemporary styling, extracting steam, grease and cooking odors quietly and efficiently.

- With four fan speeds, select the perfect extraction rate for your cooking
- Energy-efficient LED lighting to illuminate your cooking surface
- Powerful 600CFM maximum airflow

## DIMENSIONS

Height	23 3/4 - 41 1/16 "
Width	23 9/16 "
Depth	19 11/16 "

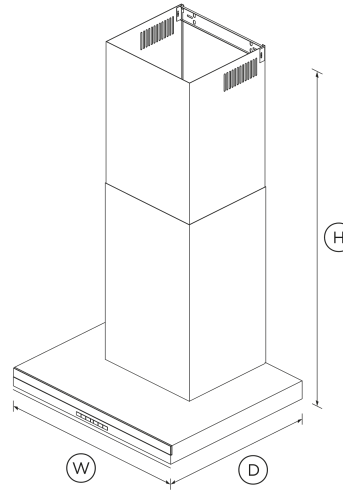

## FEATURES & BENEFITS

### Quiet And Effective

This vent hood features four fan speeds providing powerful extraction to quickly remove odours and steam. Odors can linger in the kitchen well after cooking is finished so the timer keeps the vent hood working for up to 15 minutes before automatically turning off.

### Simple Controls

This Fisher & Paykel chimney range hood features a sleek and easy to use soft-touch control panel. This range hood's LED lights provide bright, warm, energy efficient lighting ensuring the entire cooktop surface is illuminated.

### Easy Cleaning

The black glass and stainless steel finish is easily wiped clean. Multi-layered, dishwasher safe filters trap grease effectively and can easily be removed for cleaning.

### Complementary Design

This wall chimney vent hood's sleek stainless steel finish will complement any contemporary kitchen and is designed to match the rest of Fisher & Paykel's kitchen appliance family.

## SPECIFICATIONS

### Accessories (sold separately)

Chimney extension	791774
Light bulb	792579
Recirculation carbon filter	791772
Recirculation diverter	792580

### Fan ratings

Maximum sound rating	67 dBA
Speed 3 sound rating	63 dBA

### Installation and cleaning

Air outlet size	6 "
Dishwasher safe filters	2
Ducted	Top extraction
Recirculation	Optional - top extraction
Stainless steel filter cover	•
Two piece height adjustable flue	•

**Performance**

Extraction type	<b>Surface</b>
Fan speeds	<b>4</b>
Filter type	<b>Mesh</b>
Number of filters	<b>2</b>

**Power Requirements**

Rated current	<b>5.2 A</b>
Supply frequency	<b>60 Hz</b>
Supply voltage	<b>120 V</b>
Total Power	<b>542 W</b>

**Product Dimensions**

Depth	<b>19 11/16 "</b>
Height	<b>23 3/4 - 41 1/16 "</b>
Width	<b>23 9/16 "</b>

**Product information**

Control type	<b>soft-touch button</b>
--------------	--------------------------

**Ventilation features**

Light type	<b>LED</b>
Timer function	<b>•</b>

SKU	<b>50082</b>
-----	--------------

The product dimensions and specifications in this page apply to the specific product and model. Under our policy of continuous improvement, these dimensions and specifications may change at any time. You should therefore check with Fisher & Paykel's Customer Care Centre to ensure this page correctly describes the model currently available. © Fisher & Paykel Appliances Ltd 2020

**Other product downloads available at fisherpaykel.com**

- [↓ Archicad Wall RangeHood](#)
- [↓ Service & Warranty](#)
- [↓ Revit Wall RangeHood](#)
- [↓ Rhino Wall RangeHood](#)
- [↓ Sketchup Wall RangeHood](#)
- [↓ Installation & User Guide EN / Guide d'installation et guide d'utilisation FR](#)

**Where applicable:**

All appliances use energy, and energy usage typically generates carbon emissions. **Fisher & Paykel Appliances' In-use Energy Carbon Emissions Estimate** indicates carbon emissions from a product's in-use energy. This is calculated either annually or per cycle, using the product's market-specific energy label energy consumption data multiplied by the carbon emissions factor for energy in your country or region.

Our In-use Energy Carbon Emissions Estimate is designed to assist customers in making informed purchasing decisions when comparing different Fisher & Paykel products. For example, a heat pump dryer typically has a lower In-use Energy Carbon Emissions Estimate than a vented dryer.



**A PEACE OF MIND SALE**  
**24 Hours 7 Days a Week Customer Support**  
 T 1.888.936.7872 W [www.fisherpaykel.com](http://www.fisherpaykel.com)