

13.5 cu ft Series 5 Refrigerator Freezer

Series 5 | Contemporary

Stainless Steel | Left hinge

With generous storage and stylish stainless steel design with concealed handles for a more streamlined look.

- ActiveSmart™ helps keep food fresher for longer
- Ultra flat door conceals handles for a streamlined look
- Bottom freezer

DIMENSIONS

Height	67 3/4 "
Width	25 "
Depth	27 3/8 "

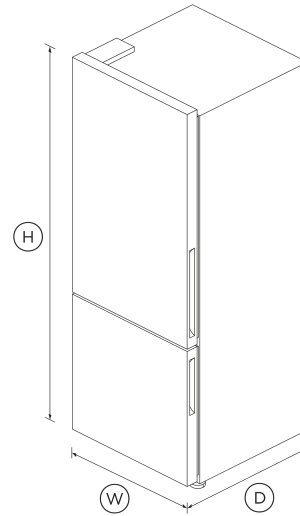

FEATURES & BENEFITS

Activesmart™ Foodcare

ActiveSmart™ Foodcare learns how you live. It's technology which understands how you use your refrigerator and adjusts temperature, airflow and humidity inside to help keep food fresher for longer.

Easy Cleaning

No more permanent dirty marks with our EZKleen feature for stainless steel refrigerators. Anti-fingerprint coating means you simply wipe clean any marks. Spill-safe secure glass shelves easily capture any drips or leaks.

Humidity Control

Your fruit and veges need different environments. The humidity control slides in each storage bin create a microclimate that helps keep food fresher for longer.

Design Quality

Our refrigerators are designed and built using quality materials. We use real stainless steel on our refrigerators and solid glass for shelving.

Clever Energy

Your refrigerator adapts to daily use by cooling and defrosting only when needed. This means your refrigerator uses the energy it needs without compromising on food care.

SPECIFICATIONS

Capacity

Total gross capacity	13.5 cu ft
Volume freezer	4 cu ft
Volume refrigerator	9.5 cu ft

Consumption

Energy rating	Energy star
Energy usage	461kWh/year
In-use energy carbon emissions estimate	56.8kgCO2e/year

Features

Adjustable door shelves	7
Adjustable glass shelves	4
Covered door shelves	2
Door alarm	•
Front levelling feet	•
Fruit and vegetable bins	2
Full extension runners	•
LED lighting	•
Rear rollers	•

Smart appliance	•
Spill proof removable bins	•
Stackable bottle holders	2

Parts and labor	2 years
Sealed system parts & labor	additional 3 years

All appliances use energy, and energy usage typically generates carbon emissions. **Fisher & Paykel Appliances' In-use Energy Carbon Emissions Estimate** indicates carbon emissions from a product's in-use energy. This is calculated either annually or per cycle, using the product's market-specific energy label energy consumption data multiplied by the carbon emissions factor for energy in your country or region.

Freezer Features

Bottle chill	•
Fast freeze	•
Large plastic bins	•

SKU	26276
-----	-------

Our In-use Energy Carbon Emissions Estimate is designed to assist customers in making informed purchasing decisions when comparing different Fisher & Paykel products. For example, a heat pump dryer typically has a lower In-use Energy Carbon Emissions Estimate than a vented dryer.

The product dimensions and specifications in this page apply to the specific product and model. Under our policy of continuous improvement, these dimensions and specifications may change at any time. You should therefore check with Fisher & Paykel's Customer Care Centre to ensure this page correctly describes the model currently available. © Fisher & Paykel Appliances Ltd 2020

Performance

ActiveSmart™ Foodcare	•
Adaptive defrost	•
Frost free	•
Sabbath mode	•



A PEACE OF MIND SALE
24 Hours 7 Days a Week Customer Support
 T 1.888.936.7872 W www.fisherpaykel.com

Other product downloads available at fisherpaykel.com

- [↓](#) 2D-DWG Freestanding Refrigerator Freezer
- [↓](#) 2D-DXF Freestanding Refrigerator Freezer
- [↓](#) Data Sheet Freestanding Refrigerator Freezer
- [↓](#) Energy Label
- [↓](#) Service & Warranty
- [↓](#) Water Filter Replacement Instructions & Installation Guide EN
- [↓](#) Installation Guide - Joiner Kit EN
- [↓](#) Guide d'installation - Instructions de Remplacement du Filtre à Eau FR
- [↓](#) Guide d'installation - kit de menuisier FR

Product dimensions

Depth	27 3/8 "
Height	67 3/4 "
Minimum air clearance at rear	1 3/16 "
Minimum air clearance each side	1 3/16 "
Minimum air clearance on top	2 "
Width	25 "

Where applicable:

Variable Temp Compartment

Bottle chill mode	•
-------------------	---

Warranty