

36" Series 7 Integrated French Door Refrigerator Freezer, Ice

Series 7 | Integrated

Panel Ready



This large capacity refrigerator with bottom freezer seamlessly integrates into your kitchen, fitting flush into your cabinetry.

- ActiveSmart™ technology helps keep food fresher for longer by constantly maintaining the ideal temperature
- Customize with your own kitchen cabinetry or purchase our stainless steel door panel accessory
- Internal ice maker with boost for busy times

- Spacious bottom freezer with full extension drawer gives easy access to frozen goods

DIMENSIONS

Height	71 13/16 "
Width	35 1/16 "
Depth	23 3/4 "

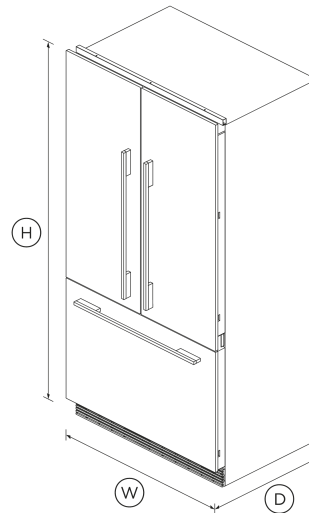

FEATURES & BENEFITS

ACTIVESMART™ FOODCARE

ActiveSmart™ Foodcare learns how you live. It's technology which understands how you use your fridge and adjusts temperature, airflow and humidity inside to help keep food fresher for longer.

Clever Energy

Your refrigerator adapts to daily use by cooling and defrosting only when needed. This means your refrigerator uses the energy it needs without compromising on food care.

ICE MAKER

Fresh ice is always available for you in a dedicated freezer bin. Simply turn it off to free up freezer space or during busy times, you can boost ice production by up to 30%.

DESIGN QUALITY

Our refrigerators are designed and built using quality materials. We use real stainless steel on our refrigerators and solid glass for shelving.

Easy Installation

Our integrated products are easy to install, whether you are renovating your kitchen or designing a new one. Our refrigerators are designed for minimal gaps with adjustable front and rear feet to allow for uneven floors alongside adjustable door panels that can be customized to match your kitchen.

Easy Cleaning

No more permanent dirty marks with our EZKleen feature for stainless steel refrigerators. Anti-fingerprint coating means you simply wipe clean any marks. Spill-safe secure glass shelves easily capture any drips or leaks.

Simple storage

This refrigerator is designed to make it simple for you to store, access and remove food. Storage bins give you full access inside when they're pulled open and can be easily removed to clean. Our flexible shelving also gives you more storage options.

SPECIFICATIONS

Accessories (sold separately)

Door panel set stainless steel	RD3672A
Handle kit Classic	AHCLRD36A
Handle kit Contemporary round, aluminium	AHS-ASBI-A
Handle kit Contemporary square fine, aluminium	AHD5RD36A
Handle kit Contemporary square fine, black	AHD5RD36AB
Handle kit Professional round flush	AHP3RD36A

Capacity

Total gross capacity	16.8 cu ft
Volume	16.8 cu ft
Volume freezer	5.1 cu ft
Volume refrigerator	11.7 cu ft

Consumption

Energy rating	Energy star
Energy usage	561kWh/year
In-use energy carbon emissions estimate	69.2kgCO2e/year

Features

Adjustable door shelves	6
Adjustable glass cantilevered shelves	•
Covered door shelves	2
Deli storage bins	1
Door alarm	•
Fruit and vegetable bins	2
LED lighting	•
Smart appliance	•
SmartTouch control panel	•

Soft close doors	•
Stackable bottle holders	4

Freezer Features

Automatic ice maker	•
Bottle chill	•
Door alarm	•
Fast freeze	•
Freezer bins	1
Ice Boost	•
LED Lighting	•
Slide Out Pastry Tray	•

Performance

ActiveSmart™ Foodcare	•
Adaptive defrost	•
Automatic defrost	•
Frost free freezer	•
Humidity control system	•
Inverter controlled compressor	•
Sabbath mode	•

Power requirements

Supply frequency	60 Hz
Supply voltage	115 V

Product dimensions

Depth	23 3/4 "
Height	71 13/16 "
Width	35 1/16 "

Warranty

Parts and labor	2 years
Sealed system parts only	5 years

SKU	26313
-----	--------------

The product dimensions and specifications in this page apply to the specific product and model. Under our policy of continuous improvement, these dimensions and specifications may change at any time. You should therefore check with Fisher & Paykel's Customer Care Centre to ensure this page correctly describes the model currently available. © Fisher & Paykel Appliances Ltd 2020

Other product downloads available at fisherpaykel.com

- [↓ 2D-DWG Integrated Refrigeration - K08 Hinge](#)
- [↓ 2D-DWG Integrated French Door Fridge Freezer](#)
- [↓ 2D-DXF Integrated Refrigeration - K08 Hinge](#)
- [↓ 2D-DXF Integrated French Door Fridge Freezer](#)
- [↓ Archicad Integrated French Door Fridge Freezer](#)
- [↓ Data Sheet Integrated French Door Fridge Freezer](#)
- [↓ Energy Label](#)
- [↓ Service & Warranty](#)
- [↓ Water Filter Replacement Instructions - Parts 847200 and 847201 - EN](#)
- [↓ Installation Guide EN](#)

- ↓ [Water Filter Replacement Instructions - Parts 847200 and 847201 - FR](#)
- ↓ [Installation Guide FR](#)
- ↓ [Planning Guide Integrated French Door Fridge Freezer](#)
- ↓ [Revit French Door Refrigerator Freezer](#)
- ↓ [Revit Integrated French Door Fridge Freezer](#)
- ↓ [Rhino French Door Refrigerator Freezer with Custom Panel](#)
- ↓ [Rhino French Door Refrigerator Freezer with Contemporary Round Handle](#)
- ↓ [Rhino French Door Refrigerator Freezer with Door Panel and Contemporary Square Fine Black Handle](#)
- ↓ [Rhino French Door Refrigerator Freezer](#)
- ↓ [Rhino French Door Refrigerator Freezer with Door Panel and Contemporary Square Handle](#)
- ↓ [Rhino French Door Refrigerator Freezer](#)
- ↓ [Rhino French Door Refrigerator Freezer with Door Panel and Professional Square Handle](#)
- ↓ [SketchUp French Door Refrigerator Freezer](#)
- ↓ [SketchUp French Door Refrigerator Freezer](#)
- ↓ [SketchUp French Door Refrigerator Freezer with Door Panel and Contemporary Square Fine Black Handle](#)
- ↓ [SketchUp French Door Refrigerator Freezer](#)
- ↓ [SketchUp French Door Refrigerator Freezer](#)
- ↓ [SketchUp French Door Refrigerator Freezer](#)
- ↓ [SketchUp French Door Refrigerator Freezer](#)
- ↓ [Sketchup Integrated French Door Fridge Freezer](#)
- ↓ [User Guide EN](#)

Our In-use Energy Carbon Emissions Estimate is designed to assist customers in making informed purchasing decisions when comparing different Fisher & Paykel products. For example, a heat pump dryer typically has a lower In-use Energy Carbon Emissions Estimate than a vented dryer.



A PEACE OF MIND SALE
24 Hours 7 Days a Week Customer Support
 T 1.888.936.7872 W www.fisherpaykel.com

Where applicable:

All appliances use energy, and energy usage typically generates carbon emissions. **Fisher & Paykel Appliances' In-use Energy Carbon Emissions Estimate** indicates carbon emissions from a product's in-use energy. This is calculated either annually or per cycle, using the product's market-specific energy label energy consumption data multiplied by the carbon emissions factor for energy in your country or region.