

12kg Series 9 Front Loader Washer, ActiveIntelligence

Series 9 | Front Load

White



Designed to handle large loads, this front loader has advanced wash functions including intuitive ActiveIntelligence™.

- With 14 wash cycles including Sports, Allergy and Wool, with extra wash options such as Soak and Time Saver
- ActiveIntelligence™ automatically optimises your cycle by adjusting the wash time and auto-dosing detergent to suit the level of soil
- 4.5 star water and energy rating

- LCD display makes washing simple, guiding you when needed

DIMENSIONS

Height	850 mm
Width	600 mm
Depth	665 mm

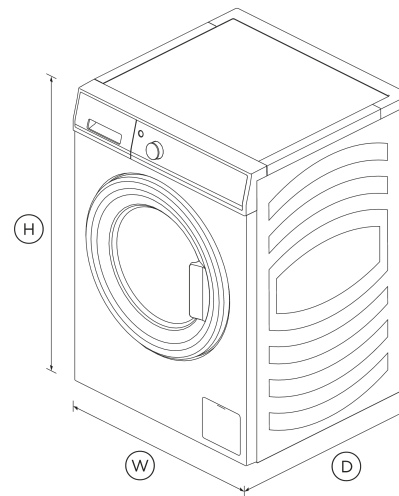

FEATURES & BENEFITS

ActiveIntelligence™ Technology

ActiveIntelligence™ technology provides ideal wash conditions. Intelligent sensors determine load size and soil level before dispensing just the right amount of detergent and adjusting the wash time, for optimal fabric care.

14 Fabric Care Cycles

Intuitive controls with clever washing hints help you get the best results. Easy to use, the LCD display provides a simple interface to select from 14 wash cycles; including Wool, Allergy, and Quick 30. The specially-designed cushioned drum provides a gentle, effective washing action, protecting clothes while delivering an optimal wash performance.

Detergent Auto-Dosing

Auto-dose mode dispenses just the right amount of liquid detergent based on the size of your load, with the added convenience of not needing to fill the dispenser for every wash.

Quick Cycles

When time is short, you can select a quick 30 minute wash without compromising cleaning and fabric care. Vortex Wash allows most cycles to take less than 1 hour to complete. Water is forced from the bottom of the drum, so detergent and heat reach your clothes faster, cleaning quickly and avoiding over-washing.

Wash Larger Loads

The large 12kg drum can wash both small and large loads as well as bulky items like a king-size feather duvet. The wide door opening makes it easy to load and unload. The benefit of a large capacity is time saving, as a full week's laundry can be done in just a few loads.

Designed To Match

The ActiveIntelligence™ washing machine and 9kg Heat Pump Condensing Dryer are designed to be the complete package for a beautiful laundry. With outstanding aesthetics and complementary wash and dry cycles, they become the perfect pair to deliver complete fabric care.

A Quiet Reliable Wash

SmartDrive™ uses electronic feedback from the direct drive motor to intelligently adjust the wash action for better fabric care. There are fewer moving parts for a reliable, quiet and efficient wash.

SPECIFICATIONS

Accessories (sold separately)

Stacking kit **Part 428159**

Capacity

Capacity **12 kg**

Features

- Add a garment (immediate door opening) •
- Anti-fungal door gasket •
- Auto out of balance correction •
- Automatic water level •
- Child/Keylock •
- Delay start •
- Door and gasket flushing •
- Eco rinse •
- Extra rinse option •
- Flood protection •
- Hot and cold water inlets •
- Interior light •
- Pre Wash •
- SmartTouch™ control dial •
- Soak •
- Spin speeds **4**
- Stainless steel drum •
- Timed liquid detergent dispenser •
- Water supply **Hot & Cold**
- Water temperature controls **5**

- Woolmark certified •
- Wrinkle Free •

Performance

- ActiveIntelligence™ technology •
- Auto soil sensing •
- Auto-dose •
- Load sensing •
- Maximum spin speed **1400 rpm**
- Number of spin speeds **4**
- SmartDrive™ technology •
- Vortex wash •

Product dimensions

- Depth **665 mm**
- Height **850 mm**
- Width **600 mm**

Warranty

- Parts only SmartDrive™ motor **10 years**

Wash Cycles

- Allergy •
- Bulky •
- Cottons •
- Delicate •
- Drum Clean •

- Easy Iron •
- Everyday •
- Heavy •
- Number of wash cycles **14**
- Quick 30 •
- Rinse •
- Sanitise •
- Spin •
- Sports •
- Towels •
- Wool •

SKU **92238**

The product dimensions and specifications in this page apply to the specific product and model. Under our policy of continuous improvement, these dimensions and specifications may change at any time. You should therefore check with Fisher & Paykel's Customer Care Centre to ensure this page correctly describes the model currently available. © Fisher & Paykel Appliances Ltd 2020

Other product downloads available at fisherpaykel.com

[↓](#) Service & Warranty

Where applicable:

All appliances use energy, and energy usage typically generates carbon emissions. **Fisher & Paykel Appliances' In-use Energy Carbon Emissions Estimate** indicates carbon emissions from a product's in-use energy. This is calculated either annually or per cycle, using the product's market-specific energy label energy consumption data multiplied by the carbon emissions factor for energy in your country or region.

Our In-use Energy Carbon Emissions Estimate is designed to assist customers in making informed purchasing decisions when comparing different Fisher & Paykel products. For example, a heat pump dryer typically has a lower In-use Energy Carbon Emissions Estimate than a vented dryer.



A PEACE OF MIND SALE
24 Hours 7 Days a Week Customer Support
T +65 6741 0777 [Wwww.fisherpaykel.com](http://www.fisherpaykel.com)