

Top Loader Washing Machine, 10kg

Series 7 | Top load

White



With plenty of room for large loads, and 12 wash cycles including Towels, this top loader caters to every type of load.

- 12 wash cycles including Allergy, Towels and Bulky
- Includes extra wash feature Soak, for helping cleaning tough stains
- Energy saving with Eco-Active™
- 4 star energy and 4 star water rating

DIMENSIONS

Height	1060 - 1090 mm
Width	685 mm
Depth	700 mm

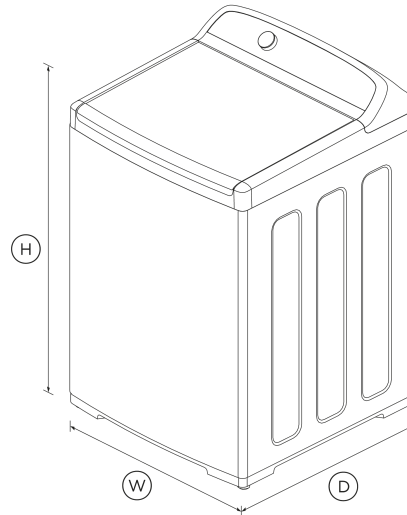

FEATURES & BENEFITS

Eco-Active™ Wash

Eco-Active™ recirculates water and detergent through clothes so less hot water is used to remove stains, dirt and bacteria.

Soft Close Lid

The tough glass lid delivers quality and durability. Its soft close mechanism makes it family safe, avoids slamming and allows for hands-free operation.

Easy To Use

This machine has a cycle to suit every type of load including Allergy, Handwash and Sheets. Select a cycle with the easy to use SmartTouch™ control dial.

Robust Construction

Designed with durable, quality materials from the real stainless steel wash basket through to the powder coated metal lid.

Quicker Drying

Drying times are reduced due to a fast spin speed of 1100RPM which helps remove more water.

Perfect Pair

Our washing machines and dryers make the perfect pair. Not only do they care for your clothes, they also look stylish together in your laundry.

SPECIFICATIONS

Capacity

Capacity **10 kg**

Consumption

Energy rating	4 star
Energy usage	380kWh/year
In-use energy carbon emissions estimate	51.5kgCO2e/year
Water consumption per cycle	102L
Water rating	4 star (WELS)

Features

Adjustable alert beeps	•
Agitator	Low profile

Auto out of balance correction	•
Automatic water level	•
Controlled cold	•
Delay start	•
Detergent dispenser	•
Fabric softener dispenser	•
Lid lock	•
No Spin / Spin hold	•
Rinse options	4
SmartTouch™ control dial	•
Soak	•
Soil levels	3
Spin speeds	3
Stainless steel drum	•
Water temperature controls	5

Performance

Auto-Lint disposal	•
Load sensing	•
Maximum spin speed	1100 rpm
Number of spin speeds	3
SmartDrive™ technology	•

Product dimensions

Depth	700 mm
Height	1060 - 1090 mm
Height (Lid open)	1420 - 1460mm
Width	685 mm

Warranty	
Parts and labour	2 years
Parts only SmartDrive™ motor	10 years

Wash Cycles

Allergy	•
Bulky	•
Conventional	•
Easy Iron	•
Eco-Active™	•
Handwash	•
Heavy	•
Number of wash cycles	12
Quick	•
Regular	•
Sheets	•
Spin	•
Towels	•

SKU 93264

The product dimensions and specifications in this page apply to the specific product and model. Under our policy of continuous improvement, these dimensions and specifications may change at any time. You should therefore check with Fisher & Paykel's Customer Care Centre to ensure this page correctly describes the model currently available. © Fisher & Paykel Appliances Ltd 2020

Other product downloads available at fisherpaykel.com

- [↓ Energy & Water Label](#)
- [↓ Service & Warranty](#)
- [↓ Installation Guide](#)
- [↓ User Guide](#)

Where applicable:

All appliances use energy, and energy usage typically generates carbon emissions. **Fisher & Paykel Appliances' In-use Energy Carbon Emissions Estimate** indicates carbon emissions from a product's in-use energy. This is calculated either annually or per cycle, using the product's market-specific energy label energy consumption data multiplied by the carbon emissions factor for energy in your country or region.

Our In-use Energy Carbon Emissions Estimate is designed to assist customers in making informed purchasing decisions when comparing different Fisher & Paykel products. For example, a heat pump dryer typically has a lower In-use Energy Carbon Emissions Estimate than a vented dryer.



A PEACE OF MIND SALE
 24 Hours 7 Days a Week Customer Support
 T 0800 372 273 [Wwww.fisherpaykel.com](http://www.fisherpaykel.com)