

90cm Series 7 Contemporary 5 Burner Dual Fuel Freestanding Cooker

Series 7 | Contemporary

Stainless Steel



A striking addition to your kitchen, with five powerful gas burners and the cooking flexibility of two convection ovens.

- Two convection ovens offer a combined capacity of 111L for ample cooking space
- Seven oven functions: Bake, Grill, Fan Forced, Fan Grill, Fan Bake, Warm, and Defrost

- Five burner gas cooktop, with precise heat control and 4kW Wok burner
- Non-tip shelves make it easy to get large dishes in and out of the oven

DIMENSIONS

Height	882 - 932 mm
Width	900 mm
Depth	600 mm

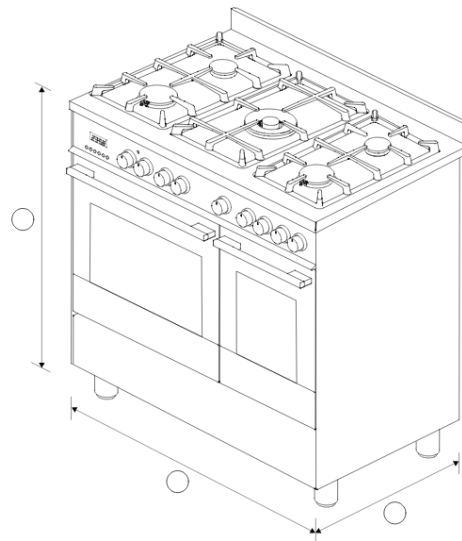

FEATURES & BENEFITS

Cooking flexibility

This freestanding dual fuel range cooker has seven functions with pre-set temperatures, including Bake, Grill and Fan Forced, allowing you to use a variety of cooking styles.

Sized to suit

Designed for multi-shelf cooking, this freestanding dual fuel cooker provides 70L of total capacity in one cavity and 40L of total capacity in the other, giving you enough room for a large family roast and all the trimmings.

Complementary design

With their black reflective glass and stainless steel finish, our freestanding range cookers are designed to match the rest of Fisher & Paykel's kitchen appliance family.

Burner power & control

The consistent flame and heat distribution of the gas burners combined with highly responsive dials offer precise heat control. Perfect a slow simmer for sauces or an intense heat for searing steaks.

Safe and sound

The door and cavity cooling system keeps the heat inside, protecting your hands and surrounding cabinetry. Additionally, the non-tip shelves make it easy to get large dishes in and out of the oven.

SPECIFICATIONS

Accessories (included)

Chromed shelf runners	2 sets
Enamel baking tray	2
Fat filter	•
Flat wire shelf	3
Grill pan handles	2
LPG conversion kit	•
Wok stand	1

Burner ratings

Auxiliary burner (natural gas)	1kW
Dual wok burner inner/outer (natural gas)	4kW
Rapid burner (natural gas)	3kW
Semi-rapid burner (natural gas)	1.75kW

Capacity

Shelf positions (main oven)	4
Shelf positions (second oven)	4
Usable capacity	111 L
Usable capacity (main oven)	70 L
Usable capacity (second oven)	41 L

Cleaning

- Acid resistant graphite enamel
- Removable oven door
- Removable shelf runners

Controls

- Automatic cooking/minute timer
- Electronic clock

Main oven features

- Internal light

Oven features

- Storage compartment

Oven functions

- Bake
- Defrost
- Fan bake
- Fan forced
- fanGrill
- Grill
- Number of functions **7**
- Warm

Power requirements

Service	19.5 A
Supply	230 V, 50Hz

Product dimensions

Depth	600 mm
Height	882 - 932 mm
Width	900 mm

Rangetop features

- Cast iron trivets
- LPG / Natural Gas compatible

Rangetop Performance

Number of burners	5
-------------------	----------

Safety

- Anti-tilt bracket
- CoolTouch door
- Flame failure system
- Non-tip shelves

Secondary oven features

- Internal light

Warranty

Parts and labour	5 years
------------------	----------------

SKU	82404
-----	--------------

The product dimensions and specifications in this page apply to the specific product and model. Under our policy of continuous improvement, these dimensions and specifications may change at any time. You should therefore check with Fisher & Paykel's Customer Care Centre to ensure this page correctly describes the model currently available. © Fisher & Paykel Appliances Ltd 2020

Other product downloads available at fisherpaykel.com

- [↓ Declaration of Conformity Freestanding Range Cooker with Dual Fuel](#)
- [↓ Energy Label](#)
- [↓ Service & Warranty](#)
- [↓ Product Information Sheet](#)
- [↓ User & Installation Guide Freestanding Cooker](#)

Where applicable:

All appliances use energy, and energy usage typically generates carbon emissions. **Fisher & Paykel Appliances' In-use Energy Carbon Emissions Estimate** indicates carbon emissions from a product's in-use energy. This is calculated either annually or per cycle, using the product's market-specific energy label energy consumption data multiplied by the carbon emissions factor for energy in your country or region.

Our In-use Energy Carbon Emissions Estimate is designed to assist customers in making informed purchasing decisions when comparing different Fisher & Paykel products. For example, a heat pump dryer typically has a lower In-use Energy Carbon Emissions Estimate than a vented dryer.



A PEACE OF MIND SALE
24 Hours 7 Days a Week Customer Support
T 08000 886 605 W www.fisherpaykel.com