

Double Oven, 30", 17 Function, Self-cleaning

Series 9 | Contemporary

Stainless Steel



Choose maximum capacity, combining two independent ovens so you can cook dishes simultaneously, with touchscreen for ease of use.

- Guided cooking using your touchscreen makes it simple to cook by food, function or recipe.
- 4.1 + 4.1 cu ft total capacity across two oven cavities, with 17 oven functions
- Non-tip, full extension sliding shelves for safe removal of hot dishes

- Accessories include food probe, smokeless grill tray, and more

DIMENSIONS

Height	48 1/2 "
Width	29 15/16 "
Depth	23 15/16 "

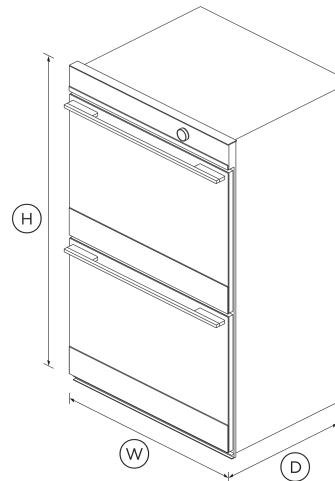

FEATURES & BENEFITS

Cook With Confidence

Our touchscreen interface provides an intuitive guided cooking experience that helps deliver perfect results, whether you've been cooking all your life or just starting out. Cook with a favorite method, a hero ingredient, or a go-to cooking function or recipe.

Generous Capacity

With an incredible 4.1 cu ft total capacity in each oven, you can create several perfectly cooked dishes at once using multiple shelves.

Multi-function flexibility

The cooking functions have each been tailored, tested, tweaked and perfected to ensure that no matter what you're cooking, you've got the right heat to match. Purchase our Wireless Temperature Sensor accessory and precisely monitor cooking in real time (accessory sold separately).

Exceptional Performance

AeroTech circulates heat evenly for a consistent temperature throughout the cavity, helping you ensure perfect results even when cooking on multiple shelves.

Self-Cleaning

Our self-clean technology breaks down food residue at a very high temperature, leaving a light ash that's easily removed with a damp cloth. The enamel coated side racks don't need to be removed when using this function.

Design Freedom

Designed to fit seamlessly into your kitchen, this built-in oven features premium materials and detailing to support a cohesive, considered kitchen design.

SPECIFICATIONS

Accessories (included)

Full extension sliding shelves	5 sets
Grill rack	1 set
Roasting dish	1
Smokeless grill tray	1
Wired temperature sensor	1

Capacity	
Shelf positions	16
Total capacity	4.1 cu ft
Usable capacity	3.6 cu ft

Cleaning	
Acid resistant graphite enamel	•
Removable oven door	•
Removable shelf runners	•

Controls	
Adjustable audio and display settings	•
Automatic cooking/minute timer	•
Automatic pre-set temperatures	•
Celsius/Fahrenheit temperature	•
Electronic clock	•
Electronic oven control	•
Food probe	•
Guided cooking by food type and recipes	•
Intuitive touchscreen display	•
Multi-language display	UK English, US English, Simplified Chinese, Français, Español
Sabbath mode with Star K certification	•
Smart appliance	•
Wi-Fi connectivity	•

Functions

Aero Broil	•
Aero™ Bake	•
Air fry	•
Bake	•
Broil	•
Classic bake	•
Dehydrate	•
Maxi Broil	•
Number of functions	17
Pastry Bake	•
Pizza bake	•
Pyrolytic self-clean	•
Rapid proof	•
Roast	•
Slow cook	•
True Aero	•
Vent bake	•
Warm	•

Performance	
AeroTech™ technology	•
Automatic rapid pre-heat	•
Broil power	4400 W
Broil width	20 mm
Broil width	20 "
Number of passes on broil	10
Number of passes on Maxi Broil	12

Power Requirements

Amperage	33.2 - 38.3 A
Supply voltage	208 / 240 V

Product Dimensions

Depth	23 15/16 "
Height	48 1/2 "
Width	29 15/16 "

Safety

ADA compliant	•
Balanced oven door	•
Catalytic venting system	•
Control panel key lock	•
CoolTouch door	•
Non-tip shelves	•

SKU	82264
-----	-------

The product dimensions and specifications in this page apply to the specific product and model. Under our policy of continuous improvement, these dimensions and specifications may change at any time. You should therefore check with Fisher & Paykel's Customer Care Centre to ensure this page correctly describes the model currently available. © Fisher & Paykel Appliances Ltd 2020

Other product downloads available at fisherpaykel.com

[↓](#) 2D-DWG Double Oven

- [↓](#) 2D-DXF Double Oven
- [↓](#) Data Sheet Double Oven
- [↓](#) Service & Warranty
- [↓](#) Installation Guide EN / Guide d'installation FR
- [↓](#) Installation Guide
- [↓](#) Revit Double Oven
- [↓](#) Rhino Double Oven
- [↓](#) Sketchup Double Oven
- [↓](#) Specification Guide Double Oven
- [↓](#) User Guide

Where applicable:

All appliances use energy, and energy usage typically generates carbon emissions. **Fisher & Paykel Appliances' In-use Energy Carbon Emissions Estimate** indicates carbon emissions from a product's in-use energy. This is calculated either annually or per cycle, using the product's market-specific energy label energy consumption data multiplied by the carbon emissions factor for energy in your country or region.

Our In-use Energy Carbon Emissions Estimate is designed to assist customers in making informed purchasing decisions when comparing different Fisher & Paykel products. For example, a heat pump dryer typically has a lower In-use Energy Carbon Emissions Estimate than a vented dryer.



A PEACE OF MIND SALE
24 Hours 7 Days a Week Customer Support
T 1.888.936.7872 W www.fisherpaykel.com