

# Single DishDrawer Dishwasher

Series 7 | Contemporary

Stainless Steel



A compact size to fit anywhere, room to wash a half load, and less bending.

- Six wash programs to suit any load, from Delicate to Heavy
- American Disabilities Act (ADA) compliant, this can be installed at an accessible height for loading and unloading.

## DIMENSIONS

Height	16 1/8 "
Width	23 9/16 "
Depth	22 9/16 "

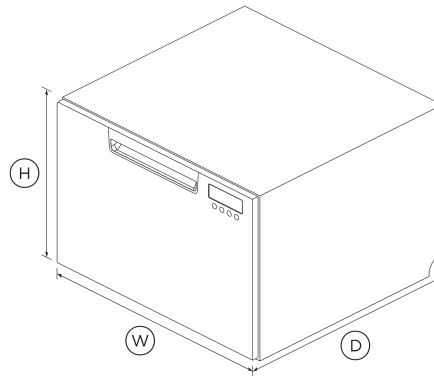

## FEATURES & BENEFITS

### Ease of use

DishDrawer™ Dishwashers are as easy to open and close as kitchen drawers and can be conveniently positioned at bench height for ease of loading and minimal bending.

### Flexible wash options

DishDrawer™ Dishwashers feature many programs including: Rinse, Fast, Delicate, Normal Eco, Normal and Heavy. These options allow the DishDrawer™ to wash everything from fine glass and crystal to heavily soiled pots and pans at the touch of a button.

### Complementary Design

DishDrawer™ Dishwashers can be installed in any kitchen space and are designed to match the Fisher & Paykel family of kitchen appliances, with matching handles, premium styling and quality materials.

### Quiet performer

Running at a very low decibel rate, these DishDrawer™ Dishwashers do their job without making a fuss. The combination of intelligent technology and simple mechanics means greater reliability and excellent wash performance.

## SPECIFICATIONS

### Accessories (included)

- Cutlery basket

### Capacity and loading

Accommodates round plates up to	11"
Fixed height, foldable cupracks	•
Fold down tines	•
Place settings	7
Place settings	7

### Consumption

Energy rating	Energy star
Energy usage	151kWh/year
In-use energy carbon emissions estimate	18.6kgCO2e/year
Water usage (per wash cycle)	1.81 gal

### Controls

Electronic fault/Diagnostic indicator	•
End of cycle beeps	•
Energy saving delay start option of up to 12 hours	•
Keylock	•
Rinse aid indicator light	•
Smart appliance	•
Wi-Fi connectivity	•

**Features**

Fan assisted drying	•
Flood protection	•
Flow through detergent dispenser	•
Motor type	<b>BLDC</b>
Quiet operation	•
SmartDrive™ technology	•

**Performance**

Noise emissions	<b>43 dBA</b>
-----------------	---------------

**Power requirements**

Amperage	<b>5A</b>
Electric circuit	<b>3 wire</b>
Rated current	<b>15 A</b>
Supply frequency	<b>60Hz</b>
Supply voltage	<b>100 - 120V</b>

**Product dimensions**

Depth	<b>22 9/16 "</b>
Height	<b>16 1/8 "</b>
Width	<b>22 9/16 "</b>

**Safety and compliance**

ADA compliant	•
---------------	---

**Warranty**

Parts and labor	<b>Limited 2 years</b>
-----------------	------------------------

**Wash Programs**

Delicate	•
Eco	•
Fast	•
Heavy	•
Medium	•
Rinse	•
Wash programs	<b>6</b>

**Water connection**

Water pressure	<b>30kPa - 1000 kPa</b>
Water supply	<b>3/8" to suit Male Compression Fitting</b>

SKU	<b>82333</b>
-----	--------------

The product dimensions and specifications in this page apply to the specific product and model. Under our policy of continuous improvement, these dimensions and specifications may change at any time. You should therefore check with Fisher & Paykel's Customer Care Centre to ensure this page correctly describes the model currently available. © Fisher & Paykel Appliances Ltd 2020

**Other product downloads available at fisherpaykel.com**

- [↓](#) 2D-DWG Single DishDrawer™ Dishwasher
- [↓](#) 2D-DXF Single DishDrawer™ Dishwasher
- [↓](#) Data Sheet Single DishDrawer™ Dishwasher
- [↓](#) Energy Label Single DishDrawer
- [↓](#) Service & Warranty
- [↓](#) Installation Guide Single DishDrawer™ Dishwasher EN
- [↓](#) Quick Start Guide
- [↓](#) Guide De Démarrage Rapide FR
- [↓](#) Revit Single DishDrawer™ Dishwasher
- [↓](#) Rhino Single DishDrawer™ Dishwasher
- [↓](#) Sketchup Single DishDrawer™ Dishwasher
- [↓](#) User Guide DishDrawer™ Dishwasher EN

**Where applicable:**

All appliances use energy, and energy usage typically generates carbon emissions. **Fisher & Paykel Appliances' In-use Energy Carbon Emissions Estimate** indicates carbon emissions from a product's in-use energy. This is calculated either annually or per cycle, using the product's market-specific energy label energy consumption data multiplied by the carbon emissions factor for energy in your country or region.

Our In-use Energy Carbon Emissions Estimate is designed to assist customers in making informed purchasing decisions when comparing different Fisher & Paykel products. For example, a heat pump dryer typically has a lower In-use Energy Carbon Emissions Estimate than a vented dryer.



**A PEACE OF MIND SALE**

24 Hours 7 Days a Week Customer Support

T 1.888.936.7872 W [www.fisherpaykel.com](http://www.fisherpaykel.com)