

60cm Series 11 Contemporary Combi-Steam Oven

Series 11 | Contemporary

Stainless Steel



This Contemporary style oven has 23 functions with additional oven accessories, to effortlessly create healthy and delicious dishes.

- With steam-only cooking functions, convection-only, or a combination of both
- 23 oven functions including Steam, Sous Vide, Air Fry and Vent Bake

- Designed to match companion products such as Vacuum Seal Drawers
- Guided touchscreen cooking makes it simple to cook by food, function or recipe

DIMENSIONS

Height	598 mm
Width	596 mm
Depth	565 mm

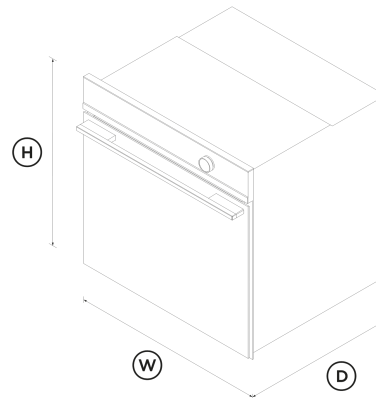

FEATURES & BENEFITS

From Steam To Sous Vide

Fine amounts of steam are released with accuracy and precision at a range of temperatures to ensure food is cooked gently and evenly. Perfect for entertaining, you can sous vide proteins such as steak and salmon before guests arrive, and simply sear when ready to serve. The flexibility of timing and accuracy of temperature control ensure perfect, predictable results every time.

Gentle And Healthy

Steam functions allow you to cook food in its own juices to retain nutrients, moisture and flavour. With five steam-only cooking functions including Sous Vide, plus four combi-steam functions, this oven lets you enjoy the benefits of flavourful and healthy restaurant-quality meals at home.

Multi-Function Flexibility

A true multi-function oven, where the advantages of steam and convection cooking can be explored in full. You have the freedom to choose - whether it's dry heat, moist heat, or a combination of the two, each cooking method creates a unique result. Purchase our Wireless Temperature Sensor accessory and precisely monitor cooking in real time (accessory sold separately).

Safe And Sound

Each function has been tailored, tested and perfected to ensure that no matter what you're cooking, you've got the right heat to match. Purchase our Wireless Temperature Sensor accessory and precisely monitor cooking in real time (accessory sold separately).

Reheat And Restore

Reduce household food waste by reheating foods with steam, which helps to regenerate moisture levels and ensure meals come out fresh and delicious. Use Steam Regenerate to reheat leftover meals such as roasts and risotto, while Crisp Regenerate is perfect for refreshing pastries, breads and pizza.

Complementary Design

Every detail has been carefully crafted from the finest materials to support a considered kitchen design. This Contemporary style oven has a stylish black finish with stainless steel contrasts, designed to help you achieve a kitchen aesthetic that suits your design style. Pair with a Vacuum Seal Drawer for the ultimate kitchen solution.

Exceptional Convection Performance

AeroTech™ circulates heat evenly for a consistent temperature throughout the cavity, while ActiveVent technology ensures optimised moisture levels when using convection functions. Achieve perfect results even when you're using multiple shelves.

SPECIFICATIONS

Accessories (included)

Chromed shelf runners	•
Descale solution	2 sachets, Part 580925
Full extension sliding shelves	2 sets
Grill rack	1 set
Large steam dish	1
Perforated large steam dish	1
Perforated small steam dish	1
Roasting dish	1
Smokeless grill tray	1
Step down wire shelf	1
Wired temperature sensor	1

Capacity

Shelf positions	6
Total capacity	85 L

Usable capacity	72 L
Water tank capacity	1.5 L

Cleaning

Acid resistant graphite enamel	•
Descale cycle	•
Drying cycle	•
Removable oven door	•
Removable oven door inner glass	•
Removable shelf runners	•
Removable water tank	•
Steam clean (oven)	•

Consumption

Energy rating	A
Energy usage	0.85kWh/cycle
In-use energy carbon emissions estimate	0.3kgCO2e/cycle

Controls

Adjustable audio and display settings	•
Audio feedback	•
Automatic cooking/minute timer	•
Automatic pre-set temperatures	•
Celsius/Fahrenheit temperature	•
Delay start	•
Electronic clock	•
Electronic oven control	•
Food probe	•

Guided cooking by food type and recipes	•
Halogen lights	•
Intuitive touchscreen display	•
Multi-language display	•

UK English, US English, Simplified Chinese, Français, Español

Sabbath mode with Federation of Synagogues certification	•
Soft close doors	•
Turned stainless steel dials with illuminated halos	•

Functions

Air fry	•
Bake	•
Classic bake	•
Crisp regenerate	•
Fan bake	•
Fan forced	•
Fan forced + High steam	•
Fan forced + Low steam	•
Fan forced + Medium steam	•
Fan grill	•
Grill	•
Number of functions	23
Pastry Bake	•
Pizza bake	•
Roast	•
Slow cook	•
Sous vide	•
Steam	•

- Steam clean (oven)
- Steam defrost
- Steam proof
- Steam regenerate
- Vent bake
- Warm

- Balanced oven door
- Catalytic venting system
- Control panel key lock
- CoolTouch door
- Non-tip shelves
- Safety thermostat

- [↓](#) Rhino Combination Steam Oven
- [↓](#) SketchUp Combination Steam Oven
- [↓](#) User Guide Combination Steam Oven EN

Performance

- ActiveVent™ system
- AeroTech™ technology
- Automatic rapid pre-heat
- Grill power **3000 W**
- SteamTechnology
- Temperature range **35°C – 230°C**
- Whisper Quiet Cooking

Warranty

Parts and labour **5 years**

SKU **82873**

The product dimensions and specifications in this page apply to the specific product and model. Under our policy of continuous improvement, these dimensions and specifications may change at any time. You should therefore check with Fisher & Paykel's Customer Care Centre to ensure this page correctly describes the model currently available. © Fisher & Paykel Appliances Ltd 2020

Other product downloads available at fisherpaykel.com

- [↓](#) 2D-DWG Combination Steam Oven
- [↓](#) 2D-DXF Combination Steam Oven
- [↓](#) ArchiCAD Combination Steam Oven
- [↓](#) Data Sheet Combination Steam Oven
- [↓](#) Energy Label Combination Steam Oven
- [↓](#) Service & Warranty
- [↓](#) Installation Guide Combination Steam Oven
- [↓](#) Product Information Sheet Combination Steam Oven
- [↓](#) Revit Combination Steam Oven

Where applicable:

All appliances use energy, and energy usage typically generates carbon emissions. **Fisher & Paykel Appliances' In-use Energy Carbon Emissions Estimate** indicates carbon emissions from a product's in-use energy. This is calculated either annually or per cycle, using the product's market-specific energy label energy consumption data multiplied by the carbon emissions factor for energy in your country or region.

Our In-use Energy Carbon Emissions Estimate is designed to assist customers in making informed purchasing decisions when comparing different Fisher & Paykel products. For example, a heat pump dryer typically has a lower In-use Energy Carbon Emissions Estimate than a vented dryer.



A PEACE OF MIND SALE
24 Hours 7 Days a Week Customer Support
 T 1800 625174 [Wwww.fisherpaykel.com](http://www.fisherpaykel.com)

Power requirements

- Amperage **15 A**
- Supply frequency **50 Hz**
- Supply voltage **220 - 240 V**

Product dimensions

- Depth **565 mm**
- Height **598 mm**
- Width **596 mm**

Safety