

Top Loader Washing Machine, 7.5kg

Series 7 | Top load

White



Running on SmartDrive™ technology for a quicker, quieter wash, you'll have plenty of room for a generous wash load.

- Six wash cycles including Quick, Wool and Delicate
- Energy saving with Eco-Active™
- 4 star energy and 3.5 star water rating

DIMENSIONS

Height	1045 mm
Width	600 mm
Depth	600 mm

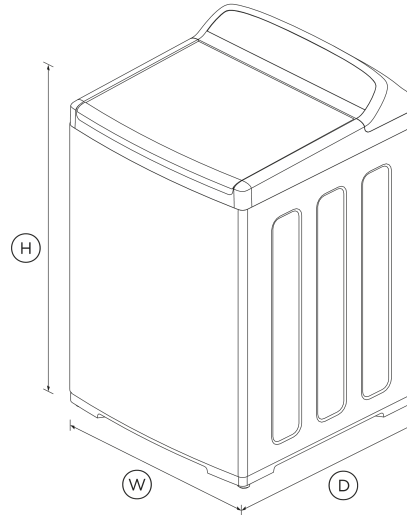

FEATURES & BENEFITS

Easy To Use

This machine has a cycle to suit every type of load including Delicate, Allergy and Wool. Select a cycle with easy-to-use SmartTouch™ controls.

Easy Installation

Self-levelling feet make installation easy and ensure the washer stays level, to reduce vibration and keep noise to a minimum.

Eco-Active™ Wash

Eco-Active™ recirculates water and detergent through clothes so less hot water is used to remove stains, dirt and bacteria.

Cares For Clothes

The flexible finned agitator ensures less tangling for superior clothes care.

Quicker Drying

Drying times are reduced due to a fast spin speed of 1100RPM, which helps remove more water.

Soft-Close Lid

The robust plastic lid has a soft close mechanism that makes it family safe, avoids slamming and allows for hands-free operation.

SPECIFICATIONS

Capacity

Capacity **7.5 kg**

Consumption

Energy rating	4 star
Energy usage	289kWh/year
In-use energy carbon emissions estimate	188.3kgCO2e/year
Water consumption per cycle	92L
Water rating	3.5 star (WELS)

Features

Adjustable alert beeps	•
Agitator	Flexible finned
Auto out of balance correction	•
Automatic water level	•
Child/Keylock	•

Controlled cold	•
Delay start	•
Detergent dispenser	•
Eco rinse	•
Fabric softener dispenser	•
Lid lock	•
Manual water levels	5
No Spin / Spin hold	•
Rinse options	3
Spin speeds	3
Stainless steel drum	•
Water temperature controls	5

Parts and labour	2 years
Parts only SmartDrive™ motor	10 years

Wash Cycles

Allergy	•
Delicate	•
Eco-Active™	•
Heavy	•
Number of wash cycles	6
Quick	•
Regular	•
Wool	•

Performance

Auto-Lint disposal	•
Detergent	Regular
Load sensing	•
Maximum spin speed	1100 rpm
Number of spin speeds	3
SmartDrive™ technology	•

SKU 92262

The product dimensions and specifications in this page apply to the specific product and model. Under our policy of continuous improvement, these dimensions and specifications may change at any time. You should therefore check with Fisher & Paykel's Customer Care Centre to ensure this page correctly describes the model currently available. © Fisher & Paykel Appliances Ltd 2020

Product dimensions

Depth	600 mm
Height	1045 mm
Height (Lid open)	1350 - 1380mm
Width	600 mm

Other product downloads available at fisherpaykel.com

- [↓](#) Energy & Water Label
- [↓](#) Service & Warranty
- [↓](#) Installation Guide
- [↓](#) User Guide

Where applicable:

All appliances use energy, and energy usage typically generates carbon emissions. **Fisher & Paykel Appliances' In-use Energy Carbon Emissions Estimate** indicates carbon emissions from a product's in-use energy. This is calculated either annually or per cycle, using the product's market-specific energy label energy consumption data multiplied by the carbon emissions factor for energy in your country or region.

Our In-use Energy Carbon Emissions Estimate is designed to assist customers in making informed purchasing decisions when comparing different Fisher & Paykel products. For example, a heat pump dryer typically has a lower In-use Energy Carbon Emissions Estimate than a vented dryer.



A PEACE OF MIND SALE
24 Hours 7 Days a Week Customer Support
 T 1300 650 590 Wwww.fisherpaykel.com

Warranty