

20.1 cu ft Series 7 French Door Refrigerator Freezer, Ice & Water

Series 7 | Contemporary

Black Stainless Steel | French hinge



Make a statement in black. With large capacity, water dispenser and ice maker, this French Door model has both style and substance.

- Brushed metal handles
- ActiveSmart™ Foodcare helps keep food fresher for longer
- Bottom freezer drawer

- EZKleen anti-fingerprint coating

DIMENSIONS

Height	70 3/4 "
Width	35 7/16 "
Depth	27 3/8 "

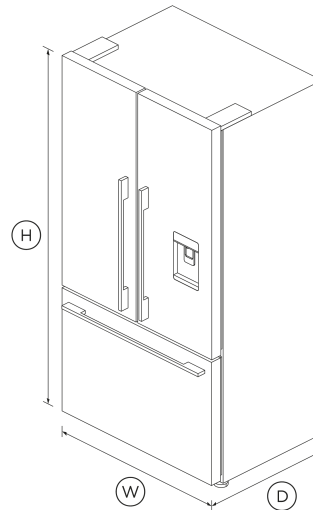

FEATURES & BENEFITS

Activesmart™ Foodcare

ActiveSmart™ technology understands that the refrigerator door is the most opened in the house. It constantly adjust temperature, airflow and humidity, maintaining an optimum environment and helping keep food fresher for longer.

Clever Energy

Your refrigerator adapts to daily use by cooling and defrosting only when needed. This means your refrigerator uses the energy it needs without compromising on food care.

Easy Cleaning

Spill-safe secure glass shelves easily capture any drips or leaks and prevent them from falling on items below.

Design Quality

Our refrigerators are designed and built using quality materials. We use real stainless steel on our refrigerators and solid glass for shelving.

Humidity Control

Your fruit and veges need different environments. The humidity control slides in each storage bin create a microclimate that helps keep food fresher for longer.

Ice Maker

The internal ice maker delivers fresh ice to a dedicated freezer bin. Simply turn it off to free up freezer space or during busy times boost ice production by up to 30%.

Ultra Slim Water Dispenser

The slimline water dispenser is easy to use. The angled water delivery means that almost any size or shape of vessel can be filled, while taking up no storage space in the door.

SPECIFICATIONS

Accessories (sold separately)

Water filter replacement	847200 - FWC3
--------------------------	---------------

Capacity

Total gross capacity	20.1 cu ft
Volume freezer	5.5 cu ft

Volume refrigerator **14.6 cu ft**

Consumption

Energy rating **Energy star**
 Energy usage **532kWh/year**
 In-use energy carbon emissions estimate **65.6kgCO2e/year**

Features

Adjustable door shelves **6**
 Adjustable glass shelves **3**
 Covered door shelves **2**
 Deli storage bins **2**
 Door alarm •
 Fruit and vegetable bins **2**
 LED lighting •
 Smart appliance •
 SmartTouch control panel •
 Soft close doors •
 Stackable bottle holders **4**
 Ultra slim water dispenser •
 Water Filter **847200**

Freezer Features

Automatic ice maker •
 Bottle chill •
 Door alarm •
 Fast freeze •
 Ice bin and scoop •

Ice Boost •
 LED Lighting •

Performance

ActiveSmart™ Foodcare •
 Adaptive defrost •
 Frost free freezer •
 Humidity control system •
 Inverter controlled compressor •
 Sabbath mode •

Product dimensions

Depth **27 3/8 "**
 Height **70 3/4 "**
 Width **35 7/16 "**

Warranty

Parts and labor **2 years**
 Sealed system parts & labor **additional 3 years**

SKU **26307**

Other product downloads available at fisherpaykel.com

- [↓ Energy Label](#)
- [↓ Service & Warranty](#)
- [↓ Water Filter Replacement Instructions & Installation Guide EN](#)
- [↓ Guide d'installation - Instructions de Remplacement du Filtre à Eau FR](#)
- [↓ Guide d'utilisation FR](#)
- [↓ Guide d'utilisation FR](#)
- [↓ Installation & User Guide ActiveSmart Refrigerator EN](#)
- [↓ Guide d'installation et guide d'utilisation FR](#)

Where applicable:

All appliances use energy, and energy usage typically generates carbon emissions. **Fisher & Paykel Appliances' In-use Energy Carbon Emissions Estimate** indicates carbon emissions from a product's in-use energy. This is calculated either annually or per cycle, using the product's market-specific energy label energy consumption data multiplied by the carbon emissions factor for energy in your country or region.

Our In-use Energy Carbon Emissions Estimate is designed to assist customers in making informed purchasing decisions when comparing different Fisher & Paykel products. For example, a heat pump dryer typically has a lower In-use Energy Carbon Emissions Estimate than a vented dryer.



A PEACE OF MIND SALE
24 Hours 7 Days a Week Customer Support
 T 1.888.936.7872 W www.fisherpaykel.com

The product dimensions and specifications in this page apply to the specific product and model. Under our policy of continuous improvement, these dimensions and specifications may change at any time. You should therefore check with Fisher & Paykel's Customer Care Centre to ensure this page correctly describes the model currently available. © Fisher & Paykel Appliances Ltd 2020