

# Series 5, Integrated Dishwasher

Series 5 | Integrated

Panel Ready



Offering a superior wash performance, this Dishwasher is panel ready and designed to be integrated into your kitchen for a seamless look.

- Customize with your own front panel and handle to match your kitchen cabinetry
- Seven wash programs to suit any load, from Delicate to Heavy
- Quick, Sanitize and Extra Dry provide extra wash options

- Flexible racking allows you to customise internal shelves to suit your needs

## DIMENSIONS

Height	32 5/16 - 36 1/2 "
Width	23 3/4 "
Depth	22 3/4 "

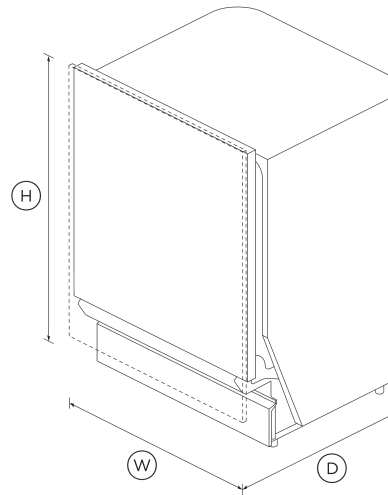

## FEATURES & BENEFITS

### Sized To Suit

Install this fully integrated dishwasher to tall (American size) or short (Euro/ADA size) counter heights, ensuring minimal gaps. Customize with a front panel to match kitchen cabinetry.

### A Quality Wash

This dishwasher offers seven wash programs including Auto, which automatically senses the optimal wash cycle for your dishes. The three stage filtration system delivers a superior clean, while the rinse aid indicator reminds you to top up for squeaky-clean dishes.

### Flexible Stacking

Designed to fit 14 place settings, the flexible, adjustable storage lets you stack even large items with ease - featuring a full width cutlery tray, height adjustable middle rack, cup holders and wine glass supports.

### Quick, Sanitize And Extra Dry Options

A Quick wash modifier results in a faster clean, while maintaining wash performance. The Sanitize option provides extra protection killing 99.9% of bacteria in the final rinse. The Extra Dry setting is perfect for plastic dishes.

### Quiet And Reliable

Running at a very low decibel rating, this dishwasher does its job without making a fuss. The combination of clever technology and simple mechanics means greater reliability and superior wash performance.

### Efficient Performance

This dishwasher is very efficient in its use of water and energy, while delivering a powerful wash that ensures optimal results.

## SPECIFICATIONS

### Accessories (included)

Kickstrip true

### Accessories (sold separately)

Door panel stainless steel AD-DW ADA  
 Handle kit Classic AHCL-DDDW-24X

Handle kit Contemporary round, aluminium	<b>AHS-OBDD-60S</b>
Handle kit Contemporary square fine, aluminium	<b>AHD5-OBDD-60SX</b>
Handle kit Contemporary square fine, black	<b>AHD5-OBDD-60SB</b>
Handle kit Contemporary square, aluminium	<b>AHD3-OBDD-60S</b>
Handle kit Professional round flush	<b>AHP3-DWDD-SX</b>
Handle kit Professional round flush, Brass off-stands	<b>AHP3DDD24BA</b>
Handle kit Professional round flush, Dark Copper off-stands	<b>AHP3DDD24DC</b>

- Energy saving delay start option of up to 12 hours
- Floor light cycle feedback
- Keylock
- Rinse aid indicator light

<b>Warranty</b>	
Parts and labor	<b>2 years</b>

**Features**

- Quiet operation
- ThermoDry system
- Three-stage filtration system
- Variable wash pressure technology

**Wash Program Modifiers**

Extra Dry	•
Half load	•
Quick	•
Sanitise	•
Wash modifiers	<b>4</b>

**Capacity and loading**

Accommodates round plates up to	<b>10 1/4"</b>
Fold down tines	•
Full width cutlery/utensil tray	•
Height adjustable rear wine glass supports	•
Pitch adjustable tines	•
Place settings	<b>14</b>
Place settings	<b>14</b>
Wine glass supports	•

**Performance**

Noise emissions	<b>46 dBA</b>
-----------------	---------------

**Wash Programs**

Auto	•
Delicate	•
Eco	•
Fast	•
Heavy	•
Medium	•
Rinse	•
Wash programs	<b>7</b>

**Power requirements**

Amperage	<b>10A</b>
Supply frequency	<b>50Hz</b>
Supply voltage	<b>220 - 240V</b>

**Consumption**

Energy rating	<b>Energy star</b>
Energy usage	<b>232kWh/year</b>
In-use energy carbon emissions estimate	<b>28.6kgCO2e/year</b>
Water usage (per wash cycle)	<b>3 gal</b>

**Product dimensions**

Depth	<b>22 3/4 "</b>
Height	<b>32 5/16 - 36 1/2 "</b>
Width	<b>23 3/4 "</b>

**Water connection**

Water pressure	<b>100kPa - 1000kPa</b>
----------------	-------------------------

**Controls**

End of cycle beeps	•
--------------------	---

**Safety and compliance**

ADA compliant	•
---------------	---

SKU	81872
-----	-------

The product dimensions and specifications in this page apply to the specific product and model. Under our policy of continuous improvement, these dimensions and specifications may change at any time. You should therefore check with Fisher & Paykel's Customer Care Centre to ensure this page correctly describes the model currently available. © Fisher & Paykel Appliances Ltd 2020



**A PEACE OF MIND SALE**  
**24 Hours 7 Days a Week Customer Support**  
T 1.888.936.7872 W [www.fisherpaykel.com](http://www.fisherpaykel.com)

#### Other product downloads available at [fisherpaykel.com](http://fisherpaykel.com)

- [↓](#) 2D-DWG Integrated Dishwasher
- [↓](#) 2D-DXF Integrated Dishwasher
- [↓](#) Energy Label
- [↓](#) Energy Label Integrated Dishwasher
- [↓](#) Service & Warranty
- [↓](#) Installation Guide EN
- [↓](#) Guide d'installation FR
- [↓](#) Planning Guide Professional Style Dial/Handle Accessories
- [↓](#) Quick Start Guide
- [↓](#) Guide De Démarrage Rapide FR
- [↓](#) User Guide
- [↓](#) Guide d'utilisation FR

#### Where applicable:

All appliances use energy, and energy usage typically generates carbon emissions. **Fisher & Paykel Appliances' In-use Energy Carbon Emissions Estimate** indicates carbon emissions from a product's in-use energy. This is calculated either annually or per cycle, using the product's market-specific energy label energy consumption data multiplied by the carbon emissions factor for energy in your country or region.

Our In-use Energy Carbon Emissions Estimate is designed to assist customers in making informed purchasing decisions when comparing different Fisher & Paykel products. For example, a heat pump dryer typically has a lower In-use Energy Carbon Emissions Estimate than a vented dryer.