

17.1 cu ft Series 5 Refrigerator Freezer, Ice & Water

Series 5 | Contemporary

Stainless Steel | Right Hinge



This stylish right hinge refrigerator has a large capacity and comes in timeless stainless steel.

- Bottom freezer drawer
- ActiveSmart™ helps keep food fresher for longer
- Brushed metal handles

DIMENSIONS

Height	67 3/4 "
Width	31 1/8 "
Depth	27 3/8 "

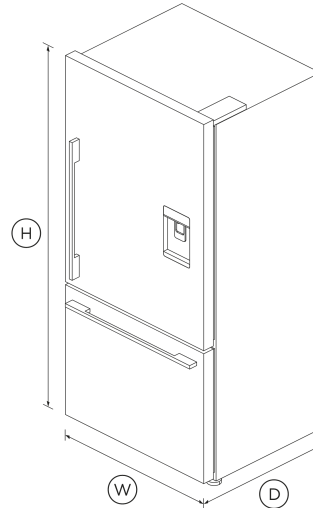

FEATURES & BENEFITS

ActiveSmart™ Foodcare

Every time you open your refrigerator, the temperature around your food changes. ActiveSmart™ foodcare adjusts airflow to create a stable temperature, helping your food stay fresher for longer.

Easy Cleaning

No more stubborn dirty marks with our EZKleen feature for stainless steel fridges. Anti-fingerprint coating means you simply wipe clean any marks. Spill-safe secure glass shelves easily capture any drips or leaks.

Design Quality

Our refrigerators are designed and built using quality materials. We use real stainless steel on our refrigerators and solid glass for shelving.

WATER ON TAP

The slimline dispenser makes it easy to fill almost any sized jug or vessel with cool filtered water and doesn't take up any storage space in your refrigerator.

Ice Maker

Fresh ice is always available for you in a dedicated freezer bin. Simply turn it off to free up freezer space or during busy times, you can boost ice production by up to 30%.

SPECIFICATIONS

Accessories (sold separately)

Joiner Kit	819264
Surround Kit (Joined left/right pair)	Part number 24476
Surround Kit (Right Hand)	Part number 24475

Capacity

Total gross capacity	17.1 cu ft
Volume freezer	4.8 cu ft
Volume refrigerator	12.3 cu ft

Consumption

Energy rating	Energy star
Energy usage	535kWh/year
In-use energy carbon emissions estimate	66.0kgCO2e/year

Features

Adjustable door shelves	14
Adjustable glass shelves	4
Covered door shelves	2
Door alarm	•
Fruit and vegetable bins	2
LED lighting	•
Smart appliance	•
SmartTouch control panel	•
Stackable bottle holders	2
Ultra slim water dispenser	•
Water Filter	Model number 836848

Freezer Features

Automatic ice maker	•
Bottle chill	•
Fast freeze	•
Ice bin and scoop	•
Ice Boost	•
Large plastic bins	•

Performance

ActiveSmart™ Foodcare	•
Adaptive defrost	•
Frost free freezer	•
Humidity control system	•
Sabbath mode	•

Power requirements

Rated current	10 A
Supply frequency	60 Hz
Supply voltage	115 V

Product dimensions

Depth	27 3/8 "
Height	67 3/4 "
Minimum air clearance at rear	1 3/16 "
Minimum air clearance each side	1 3/16 "
Width	31 1/8 "

Warranty

Parts and labor	2 years
Sealed system parts & labor	additional 3 years

SKU	26298
-----	-------

The product dimensions and specifications in this page apply to the specific product and model. Under our policy of continuous improvement, these dimensions and specifications may change at any time. You should therefore check with Fisher & Paykel's Customer Care Centre to ensure this page correctly describes the model currently available. © Fisher & Paykel Appliances Ltd 2020

Other product downloads available at fisherpaykel.com

[↓](#) 2D-DWG Freestanding Refrigerator Freezer

- [↓](#) 2D-DXF Freestanding Refrigerator Freezer
- [↓](#) Data Sheet Freestanding Refrigerator Freezer
- [↓](#) Energy Label
- [↓](#) Service & Warranty
- [↓](#) Water Filter Replacement Instructions - Parts 847200 and 847201 - EN
- [↓](#) Installation Guide - Quick Reference EN
- [↓](#) Water Filter Replacement Instructions - Parts 862285 and 862288 - EN
- [↓](#) Installation Guide Refrigerator Freezer EN
- [↓](#) Installation Guide - Joiner Kit EN
- [↓](#) Water Filter Replacement Instructions - Parts 847200 and 847201 - FR
- [↓](#) Water Filter Replacement Instructions - Parts 862285 and 862288 - FR
- [↓](#) Installation Guide - Joiner Kit FR
- [↓](#) User Guide Refrigerator Freezer EN
- [↓](#) User Guide Refrigerator Freezer FR

Where applicable:

All appliances use energy, and energy usage typically generates carbon emissions. **Fisher & Paykel Appliances' In-use Energy Carbon Emissions Estimate** indicates carbon emissions from a product's in-use energy. This is calculated either annually or per cycle, using the product's market-specific energy label energy consumption data multiplied by the carbon emissions factor for energy in your country or region.

Our In-use Energy Carbon Emissions Estimate is designed to assist customers in making informed purchasing decisions when comparing different Fisher & Paykel products. For example, a heat pump dryer typically has a lower In-use Energy Carbon Emissions Estimate than a vented dryer.



A PEACE OF MIND SALE

24 Hours 7 Days a Week Customer Support

T 1.888.936.7872 W www.fisherpaykel.com