

# Double DishDrawer Dishwasher, Tall, Sanitize

Series 7 | Contemporary

Stainless Steel



Doing the dishes got easier. Load one drawer while the other washes - with the top drawer fitting your large dinner plates easily.

- Six wash programs, as well as additional Quick wash, Sanitize and Extra Dry options
- Built-in water softener improves wash performance by reducing unwanted minerals in the water
- Flexible racking can be folded down to fit bigger dishes

## DIMENSIONS

Height	34 - 36 3/8 "
Width	23 9/16 "
Depth	22 9/16 "

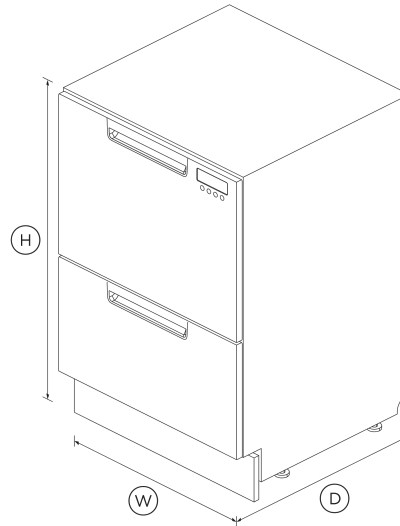

## FEATURES & BENEFITS

### Ease of use

DishDrawer™ Dishwashers are as easy to open and close as kitchen drawers and can be conveniently positioned at bench height for ease of loading and minimal bending. Flexible racking allows you to make adjustments to fit in a variety of dishes.

### Independent wash

With the ability to use both drawers independently and select different wash programs the DishDrawer™ Dishwasher can wash everything from fine glass and crystal to heavily soiled pots and pans.

### Quick, Sanitize and Extra Dry options

The Quick wash modifier delivers a faster wash while maintaining performance. The Sanitize option provides extra protection killing 99.9% of bacteria in the final rinse. The Extra Dry setting is perfect for plastic dishes.

### Quiet performer

Running at a very low decibel rating, these DishDrawer™ dishwashers do their job without making a fuss. The combination of intelligent technology and simple mechanics means greater reliability and excellent wash performance.

## SPECIFICATIONS

### Accessories (included)

Cutlery basket	•
Kickstrip	true
Knife clip and multipurpose clip	•

### Capacity and loading

Accommodates round plates up to	12.25" (top) 11" (bottom)
Adjustable height, foldable cupracks	•
Fold down tines	•
Pitch adjustable tines	•
Place settings	14
Place settings	14
Place settings per drawer	7
Place settings per drawer	7

### Controls

Electronic fault/Diagnostic indicator	•
---------------------------------------	---

End of cycle beeps	•
Energy saving delay start option of up to 12 hours	•
Keylock	•
Rinse aid indicator light	•
Wi-Fi connectivity	•

Height	<b>34 - 36 3/8 "</b>
Width	<b>23 9/16 "</b>

SKU **82332**

<b>Warranty</b>	
Parts and labor	<b>Limited 2 years</b>

The product dimensions and specifications in this page apply to the specific product and model. Under our policy of continuous improvement, these dimensions and specifications may change at any time. You should therefore check with Fisher & Paykel's Customer Care Centre to ensure this page correctly describes the model currently available. © Fisher & Paykel Appliances Ltd 2020

**Features**

Built-in water softener	•
Fan assisted drying	•
Flood protection	•
Flow through detergent dispenser	•
Motor type	<b>BLDC</b>
Quiet operation	•
SmartDrive™ technology	•

**Wash Program Modifiers**

Extra Dry	•
Quick	•
Sanitise	•
Wash modifiers	<b>3</b>

**Other product downloads available at fisherpaykel.com**

- [↓](#) 2D-DWG Double DishDrawer™ Dishwasher
- [↓](#) 2D-DXF Double DishDrawer™ Dishwasher
- [↓](#) Data Sheet Double DishDrawer™ Dishwasher
- [↓](#) Energy Label Double DishDrawer™ Dishwasher
- [↓](#) Service & Warranty
- [↓](#) Installation Guide Double DishDrawer™ Dishwasher
- [↓](#) Guide De Démarrage Rapide FR
- [↓](#) Revit Double DishDrawer™ Dishwasher
- [↓](#) Rhino Double DishDrawer™ Dishwasher
- [↓](#) Sketchup Double DishDrawer™ Dishwasher
- [↓](#) Specification Guide DoubleDishDrawer™ Dishwasher
- [↓](#) User Guide DishDrawer™ Dishwasher EN

**Performance**

Noise on standard cycle top drawer	<b>42 dBA</b>
------------------------------------	---------------

**Wash Programs**

Delicate	•
Eco	•
Fast	•
Heavy	•
Medium	•
Rinse	•
Wash programs	<b>6</b>

**Power requirements**

Amperage	<b>10A</b>
Electric circuit	<b>3 wire</b>
Rated current	<b>15 A</b>
Supply frequency	<b>60Hz</b>
Supply voltage	<b>100 - 120V</b>

**Water connection**

Supplied hose to suit 3/8" (9mm) male compression fitting	•
Water pressure	<b>100kPa - 1000kPa</b>
Water supply	<b>3/8" to suit Male Compression Fitting</b>

**Where applicable:**

All appliances use energy, and energy usage typically generates carbon emissions. **Fisher & Paykel Appliances' In-use Energy Carbon Emissions Estimate** indicates carbon emissions from a product's in-use energy. This is calculated either annually or per cycle, using the product's market-specific energy label energy consumption data multiplied by the carbon emissions factor for energy in your country or region.

**Product dimensions**

Depth	<b>22 9/16 "</b>
-------	------------------

Our In-use Energy Carbon Emissions Estimate is designed to assist customers in making informed purchasing decisions when comparing different Fisher & Paykel products. For example, a heat pump dryer typically has a lower In-use Energy Carbon Emissions Estimate than a vented dryer.



**A PEACE OF MIND SALE**  
24 Hours 7 Days a Week Customer Support  
T 1.888.936.7872 W [www.fisherpaykel.com](http://www.fisherpaykel.com)