

# Combination Microwave Oven, 76cm, 22 Function

Series 9 | Contemporary

Black Glass



The speed of microwave cooking with the versatility of convection oven technology, designed for perfect pairing with other companion products such as a steam oven or warming drawer.

- Generous 49L capacity, with four shelf positions
- With four microwave-only functions, 14 traditional oven functions, and four combination functions
- Guided touchscreen cooking makes it simple to navigate cooking processes

- Wi-Fi enabled and works with the SmartHQ™ app for remote control and notifications

## DIMENSIONS

Height	458 mm
Width	760 mm
Depth	565 mm

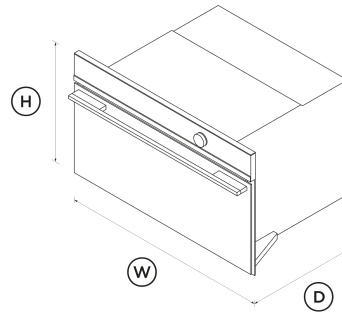

## SPECIFICATIONS

### Accessories (included)

Chromed shelf runners	•
Glass tray	1
Grill rack	1 set
Step down wire shelf	1

Wire shelf	1
Wired temperature sensor	1

### Capacity

Shelf positions	4
Total capacity	49 L
Usable capacity	38 L

### Cleaning

- Acid resistant graphite enamel
- Drop down grill element
- Drying cycle
- Easy to clean interior
- Removable shelf runners

### Controls

- Adjustable audio and display settings
- Audio feedback
- Automatic cooking/minute timer
- Automatic pre-set temperatures
- Celsius/Fahrenheit temperature
- Certified Sabbath mode
- Delay start
- Dial with illuminated halo
- Electronic capacitive touch controls
- Electronic clock
- Electronic oven control
- Food probe

- Guided cooking by food type and recipes •
- Halogen lights •
- Intuitive touchscreen display •
- Microwave timer •
- Multi-language display **true**
- Push-to-open drawer •
- Smart appliance •
- Soft close doors •
- Touch control glass interface •
- True convection oven •
- Turned stainless steel dials with illuminated halos •
- Wi-Fi connectivity •

- Rapid proof •
- Roast •
- Roast + Micro (2 levels) •
- Slow cook •
- Vent bake •
- Warm •

---

**Performance**

- ActiveVent™ system •

---

**Power requirements**

Amperage	<b>16 A</b>
Supply frequency	<b>50 Hz</b>
Supply voltage	<b>220-240 V</b>

---

**Product dimensions**

Depth	<b>565 mm</b>
Height	<b>458 mm</b>
Width	<b>760 mm</b>

---

SKU **84769**

---

The product dimensions and specifications in this page apply to the specific product and model. Under our policy of continuous improvement, these dimensions and specifications may change at any time. You should therefore check with Fisher & Paykel's Customer Care Centre to ensure this page correctly describes the model currently available. © Fisher & Paykel Appliances Ltd 2020

**Other product downloads available at fisherpaykel.com**

- [↓](#) 2D-DWG Combination Microwave Oven
- [↓](#) 2D-DWG Combination Microwave Oven
- [↓](#) 2D-DXF Combination Microwave Oven
- [↓](#) 2D-DXF Combination Microwave Oven
- [↓](#) Service & Warranty
- [↓](#) Planning Guide - 76cm Built-in Ovens and Companions - Contemporary Black

**Where applicable:**

All appliances use energy, and energy usage typically generates carbon emissions. **Fisher & Paykel Appliances' In-use Energy Carbon Emissions Estimate** indicates carbon emissions from a product's in-use energy. This is calculated either annually or per cycle, using the product's market-specific energy label energy consumption data multiplied by the carbon emissions factor for energy in your country or region.

Our In-use Energy Carbon Emissions Estimate is designed to assist customers in making informed purchasing decisions when comparing different Fisher & Paykel products. For example, a heat pump dryer typically has a lower In-use Energy Carbon Emissions Estimate than a vented dryer.



**A PEACE OF MIND SALE**  
**24 Hours 7 Days a Week Customer Support**  
 T 0800 372 273 W [www.fisherpaykel.com](http://www.fisherpaykel.com)