

# 76cm Series 9 Professional Compact Combi-Steam Oven

Series 9 | Professional

Stainless Steel

Designed for the home chef, our Combination Steam Oven simplifies the creation of healthy and delicious meals. It pairs seamlessly with companion products like the Vacuum Seal Drawer and Warming Drawer.

- 23 oven functions including Steam, Sous Vide, Air Fry and Crisp Regenerate
- Guided touchscreen cooking makes it simple to cook using various functions, recipes, and food types
- Help reduce food waste by rejuvenating leftovers with steam for fresh-tasting roasts, and risottos and more
- Pair with our Vacuum Seal Drawer companion product for effortless Sous Vide preparation

## DIMENSIONS

Height	458 mm
Width	757 mm
Depth	575 mm

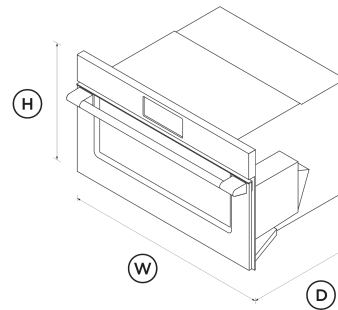

## FEATURES & BENEFITS

### Combination cooking

Elevate every ingredient with combination steam cooking. By blending dry convection heat with adjustable steam levels, you can preserve the delicate texture of seafood like salmon and snapper, maintain the essential vitamins and minerals in greens, and enhance the rich flavours of prime cuts of meat.

### Mastery of temperature

Steam is eight times more efficient at conducting heat than convection, which means our combi steam oven can cook at reduced times and lower temperatures. It perfectly balances steam with convection heat, ensuring exceptional temperature accuracy for perfect roasting and crafting signature dishes.

### Preserve flavour and nutrients

Perfect for delicate dishes like snapper or salmon, steam cooking preserves nutrients and texture, offering a healthier way to enjoy meals. With specialised steam functions, including Sous Vide, the combi steam oven brings out the best in every ingredient, ensuring your creations are both nutritious and delicious.

### Cook with confidence

Using the large 5" touchscreen interface, you can cook with a favourite method, hero ingredient, cooking function, or recipe. Your oven will guide you through the steps, or change the temperature and heat type automatically, depending on your selection.

### Reheat and restore

Revitalise your leftovers with our Steam Regenerate function, ensuring dishes like roast chicken and risotto maintain their freshness and flavour. For that just-baked quality in pastries, bread, and pizza, opt for our Crisp Regenerate setting, which reheats to keep every bite deliciously crispy.

### Complementary design

Every detail has been carefully crafted from the finest materials to enhance your kitchen's aesthetic, perfectly suiting your design style. Pair it with a Vacuum Seal Drawer for the ultimate kitchen solution.

### Steam clean

Keep your oven spotless with the natural power of steam. The steam clean feature helps tackle stubborn spills, allowing for a quick wipe-down.

## SPECIFICATIONS

### Accessories (included)

Catalytic panels	•
Descale solution	2
Flat brushed baking tray	1

Full extension sliding shelves	1	Audio feedback	•	Fan forced + Medium steam	•
Grill rack	1 set	Automatic cooking/minute timer	•	Grill	•
Large steam dish	1	Automatic pre-set temperatures	•	Pastry Bake	•
Perforated large steam dish	1	Celsius/Fahrenheit temperature	•	Pizza bake	•
Perforated small steam dish	1	Certified Sabbath mode	•	Roast	•
Roasting dish	1	Delay start	•	Slow cook	•
Wire shelf	1	Electronic capacitive touch controls	•	Sous vide	•
Wired temperature sensor	1	Electronic clock	•	Steam	•
<hr/>		Electronic oven control	•	Steam clean (oven)	•
<b>Capacity</b>		Food probe	•	Steam defrost	•
Shelf positions	4	Guided cooking by food types	•	Steam proof	•
Total capacity	55 L	Halogen lights	•	Steam regenerate	•
Usable capacity	45 L	Intuitive touchscreen display	•	Vent bake	•
Water tank capacity	1.4 L	Multi-language display	true	Warm	•
<hr/>		Smart appliance	•	<hr/>	
<b>Cleaning</b>		Soft close doors	•	<b>Performance</b>	
Acid resistant graphite enamel	•	Touch control glass interface	•	ActiveVent™ system	•
Descale cycle	•	True convection oven	•	AeroTech™ technology	•
Drying cycle	•	Voice control	•	Automatic rapid pre-heat	•
Easy to clean interior	•	Wireless temperature sensor compatible	•	Automatic sensor cooking	•
Removable oven door	•	<hr/>		Temperature range	35 - 230
Removable oven door inner glass	•	<b>Functions</b>		<hr/>	
Removable shelf runners	•	Air fry	•	<b>Power requirements</b>	
Removable water tank	•	Bake	•	Amperage	20 A
Steam clean (oven)	•	Classic bake	•	Supply frequency	50 Hz
<hr/>		Crisp regenerate	•	Supply voltage	220-240 V
<b>Controls</b>		Fan bake	•	<hr/>	
Adjustable audio and display settings	•	Fan forced	•	<b>Product dimensions</b>	
		Fan forced + High steam	•		
		Fan forced + Low steam	•		

Depth	<b>575 mm</b>
Height	<b>458 mm</b>
Width	<b>757 mm</b>

---

SKU	82612
-----	-------

---

Our In-use Energy Carbon Emissions Estimate is designed to assist customers in making informed purchasing decisions when comparing different Fisher & Paykel products. For example, a heat pump dryer typically has a lower In-use Energy Carbon Emissions Estimate than a vented dryer.



**A PEACE OF MIND SALE**  
**24 Hours 7 Days a Week Customer Support**  
T 0800 372 273 W [www.fisherpaykel.com](http://www.fisherpaykel.com)

The product dimensions and specifications in this page apply to the specific product and model. Under our policy of continuous improvement, these dimensions and specifications may change at any time. You should therefore check with Fisher & Paykel's Customer Care Centre to ensure this page correctly describes the model currently available. © Fisher & Paykel Appliances Ltd 2020

#### Other product downloads available at [fisherpaykel.com](http://fisherpaykel.com)

- [↓](#) 2D-DWG Combination Steam Oven
- [↓](#) 2D-DXF Combination Steam Oven
- [↓](#) Service & Warranty
- [↓](#) Planning Guide - 76cm Built-in Ovens and Companions - Professional

#### Where applicable:

All appliances use energy, and energy usage typically generates carbon emissions. **Fisher & Paykel Appliances' In-use Energy Carbon Emissions Estimate** indicates carbon emissions from a product's in-use energy. This is calculated either annually or per cycle, using the product's market-specific energy label energy consumption data multiplied by the carbon emissions factor for energy in your country or region.