

60cm Series 7 Contemporary Compact Combi-Microwave Oven

Series 7 | Contemporary

Stainless Steel



The speed of microwave cooking with the versatility of convection oven technology in a compact companion model.

- Compact size, and generous 49L capacity with four shelf positions
- Intuitive, 2.4" display with illuminated dial

DIMENSIONS

Height	458 mm
Width	596 mm
Depth	565 mm

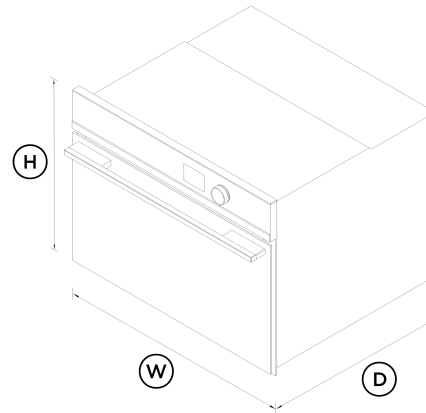

FEATURES & BENEFITS

Cooking Flexibility

Choose from 19 cooking functions including Fan Forced and Grill. With both microwave and convection oven technology in the same oven, you have more flexibility for your culinary creations.

Sized To Suit

A compact 60cm width means this microwave oven can be placed almost anywhere - all companion products can be installed at a convenient height to suit your kitchen design and preference.

Easy To Use

The intuitive display shows you all the information you need, allowing you to easily program in your desired cooking mode and duration.

Complementary Design

Finished in a stylish stainless steel, our Contemporary style companion products help you achieve a coherent kitchen aesthetic that suits your design style.

Easy Cleaning

This Convection Microwave Oven features easily removable side racks and an enamel interior for easy cleaning.

Safe And Sound

The CoolTouch door is safe to touch from the outside, protecting your hands and the surrounding cabinetry.

SPECIFICATIONS

Accessories (included)

Chromed shelf runners	•
Glass tray	1
Grill rack	1 set
Step down wire shelf	1
Wire shelf	1

Capacity

Shelf positions	4
Total capacity	49 L
Usable capacity	38 L

Cleaning

- Acid resistant graphite enamel
- Drying cycle
- Easy to clean interior
- Removable shelf runners

Controls

- Adjustable audio and display settings
- Audio feedback
- Automatic cooking/minute timer
- Automatic pre-set temperatures
- Celsius/Fahrenheit temperature
- Certified Sabbath mode
- Delay start
- Dial with illuminated halo
- Electronic capacitive touch controls
- Electronic clock
- Electronic oven control
- Guided cooking
- Halogen lights
- LED display
- Microwave timer
- Multi-language display

UK English, US English, Simplified Chinese, Français, Español

- Push-to-open drawer
- Soft close doors
- True convection oven
- Turned stainless steel dials with illuminated halos

Functions

- Air fry
- Bake
- Defrost
- Fan bake
- Fan forced
- Fan forced + Micro
- Fan forced + Micro (2 levels)
- Fan grill
- Fan grill + Micro (2 levels)
- Grill
- Grill + Micro (2 levels)
- Microwave + grill
- Microwave cooking
- Pastry Bake
- Pizza bake
- Popcorn
- Quick start
- Roast
- Roast + Micro (2 levels)
- Slow cook
- Vent bake

Performance

- ActiveVent™ system
- AeroTech™ technology
- Automatic rapid pre-heat
- Grill power **3000 W**
- Microwave power **900 W**
- Microwave power levels **6**

- Temperature range **35 - 230°**
- Whisper quiet cooking

Power requirements

- Amperage **16 A**
- Supply frequency **50 Hz**
- Supply voltage **220-240 V**

Product dimensions

- Depth **565 mm**
- Height **458 mm**
- Width **596 mm**

Safety

- Balanced oven door
- Control panel key lock
- CoolTouch door
- Non-tip shelves
- Safety thermostat

SKU 82702

The product dimensions and specifications in this page apply to the specific product and model. Under our policy of continuous improvement, these dimensions and specifications may change at any time. You should therefore check with Fisher & Paykel's Customer Care Centre to ensure this page correctly describes the model currently available. © Fisher & Paykel Appliances Ltd 2020

Other product downloads available at fisherpaykel.com

- [↓](#) 2D-DWG Combination Microwave Oven
- [↓](#) 2D-DWG Combination Microwave Oven
- [↓](#) 2D-DXF Combination Microwave Oven
- [↓](#) 2D-DXF Combination Microwave Oven
- [↓](#) Data Sheet Combination Microwave Oven
- [↓](#) Service & Warranty
- [↓](#) Planning Guide Contemporary Combination Microwave Oven
- [↓](#) Preliminary Specification Guide Microwave

Where applicable:

All appliances use energy, and energy usage typically generates carbon emissions. **Fisher & Paykel Appliances' In-use Energy Carbon Emissions Estimate** indicates carbon emissions from a product's in-use energy. This is calculated either annually or per cycle, using the product's market-specific energy label energy consumption data multiplied by the carbon emissions factor for energy in your country or region.

Our In-use Energy Carbon Emissions Estimate is designed to assist customers in making informed purchasing decisions when comparing different Fisher & Paykel products. For example, a heat pump dryer typically has a lower In-use Energy Carbon Emissions Estimate than a vented dryer.