

Internal Blower

Series 7 | Professional

Stainless Steel

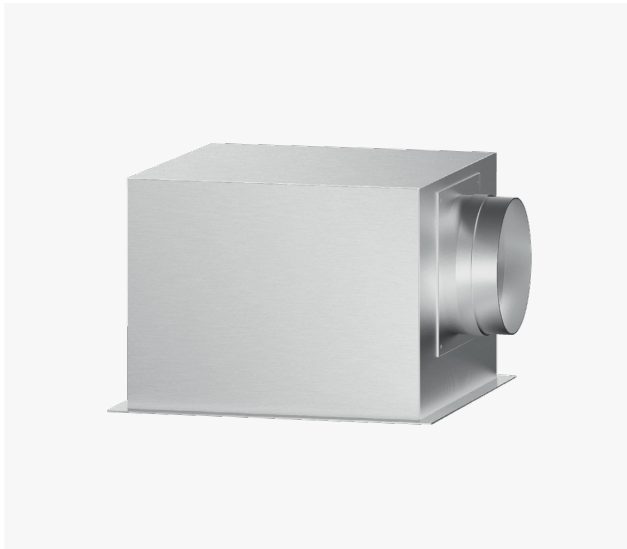

This remote internal blower can be placed anywhere, working with one of our downdraft range hoods for faster and more efficient extraction.

- Can be paired with our downdraft range hoods, such as models HD36 and HD30
- Powerful 600CFM maximum airflow

DIMENSIONS

Height 13 "

Width 10 "
Depth 13 "

Height 13 "
Width 10 "

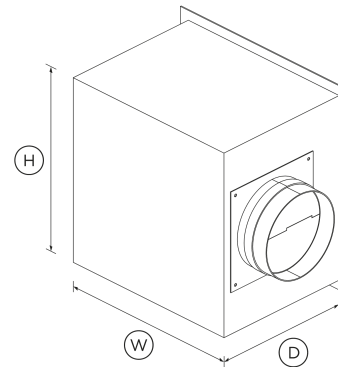

SPECIFICATIONS

Installation and cleaning

Air outlet size 10" "

Power requirements

Rated current 15 A
Supply frequency 60 Hz
Supply voltage 120 V

Product dimensions

Depth 13 "

SKU 50046

The product dimensions and specifications in this page apply to the specific product and model. Under our policy of continuous improvement, these dimensions and specifications may change at any time. You should therefore check with Fisher & Paykel's Customer Care Centre to ensure this page correctly describes the model currently available. © Fisher & Paykel Appliances Ltd 2020

Other product downloads available at fisherpaykel.com

- [↓ Archicad Internal Blower](#)
- [↓ Service & Warranty](#)
- [↓ Revit Internal Blower](#)
- [↓ Rhino Internal Blower](#)
- [↓ Sketchup Internal Blower](#)
- [↓ Installation & User Guide EN / Guide d'installation et guide d'utilisation FR](#)

Where applicable:

All appliances use energy, and energy usage typically generates carbon emissions. **Fisher & Paykel Appliances' In-use Energy Carbon Emissions Estimate** indicates carbon emissions from a product's in-use energy. This is calculated either annually or per cycle, using the product's market-specific energy label energy consumption data multiplied by the carbon emissions factor for energy in your country or region.

Our In-use Energy Carbon Emissions Estimate is designed to assist customers in making informed purchasing decisions when comparing different Fisher & Paykel products. For example, a heat pump dryer typically has a lower In-use Energy Carbon Emissions Estimate than a vented dryer.



A PEACE OF MIND SALE
24 Hours 7 Days a Week Customer Support
T 1.888.936.7872 W www.fisherpaykel.com