

# Freestanding Cooker, Induction, 90cm, 5 Zones with SmartZone, Self-cleaning

Series 9 | Classic

White



With large oven and cooktops that can be paired to create an expansive cook zone, this is a range made for those who love to cook.

- Five cooking zones that can be bridged to form SmartZones

- Convection oven with 140L total capacity, nine oven functions plus rotisserie, including Pastry Bake with pizza mode and rapid proof for making bread
- Non-tip full-extension shelves for safe removal of hot dishes
- High-temperature self-cleaning function breaks down food residue for an easy clean

## DIMENSIONS

Height	898 - 946 mm
Width	897 mm
Depth	600 mm

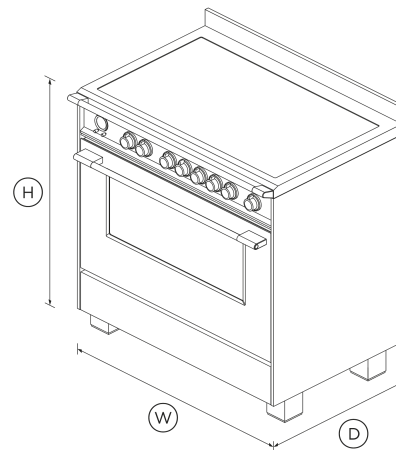

## FEATURES & BENEFITS

Multi-Shelf Cooking

Our AeroTech™ system circulates air evenly throughout the entire oven so dishes on the top shelf turn out just as perfectly as food cooking on the bottom shelf.

### Power & Control

Instant and immediate control from the highest to the gentlest heat. The finely tuned cooktop controls let you sear, stir fry or simmer a delicate sauce to perfection.

### Easy To Clean

Cleaning up spills is effortless. Your cooktop simply needs a quick wipe to keep it looking good as new. The pyrolytic self-clean oven cycle breaks down food residue at a very high temperature, leaving a light ash that's easily removed with a damp cloth.

### Even Heat

Accurate, electronically-controlled oven heat ensures a great result every time.

### Quality And Durability

Every detail has been carefully crafted. The solid, perfectly balanced soft-close door, durable cooktop and glowing halo dials all add up to an exceptional, premium range.

### Large Capacity Oven

The generous 140L total capacity oven gives you plenty of space to cook multiple dishes at once.

## SPECIFICATIONS

### Accessories (included)

Flat wire shelf	1
Full extension sliding shelves	2 sets (part 578744)
Full extension telescopic shelves	2 sets (part 578744)
Grill rack	true

Roasting dish	1
Rotisserie set	1 set
Step down wire shelf	•

**Accessories (sold separately)**

Kick strip, white (optional)	KICKOR90W1
------------------------------	------------

**Capacity**

Shelf positions (main oven)	6
Total capacity	140 L
Usable capacity (main oven)	121 L

**Cleaning**

Acid resistant graphite enamel	•
Drop down grill element	•
Flat easy clean glass surface	•
Pyrolytic proof shelf runners	•
Pyrolytic self-clean	•
Removable oven door	•
Removable oven door inner glass	•
Removable shelf runners	•

**Controls**

Audio feedback	•
Automatic cooking/minute timer	•
Automatic pre-set temperatures	•
Celsius/Fahrenheit temperature	•

Electronic clock	•
High resolution display	•
Laser etched graphics	•
Precise electronic temperature control	•
Sabbath mode	•
Toughened fused glass graphics	•
Turned stainless steel clock buttons	•
Turned stainless steel clock crown (dial)	•

**Installation Dimensions**

Installation cutout dimensions (Depth)	600 mm
Installation cutout dimensions (Width)	900 mm

**Oven features**

AeroTech™ technology	•
Automatic rapid pre-heat	•
Bright chromed, cast zinc dials with illuminated halos	•
Electronic oven control	•
Internal light	4 x 25W halogen (2 side & 2 top)
Soft open/close door	•
True convection	•
Twin cavity fans	•
Warming drawer	•

**Oven functions**

Bake	•
Fan bake	•

Fan forced	•
fanGrill	•
Grill	•
Number of functions	9
Pastry Bake with Pizza mode	•
Rapid proof	•
Roast	•
Rotisserie	•
True convection	•

**Oven performance**

CoolTouch door	Quadruple glazed
Warming drawer power	202 W

**Power requirements**

Amperage	68 A
Supply frequency	50 Hz
Supply voltage	220 - 240 V

**Product details**

Self Cleaning Sf	Yes
------------------	-----

**Product dimensions**

Depth	600 mm
Height	898 - 946 mm
Width	897 mm

**Rangetop features**

Auto heat reduce	•
Dual colour display	•
Gentle heat	•
Heat settings	9
Hob rail	•
Hob rear trim	60 mm
Induction cooking technology	•
SmartZone	1
Zone bridging	•

**Rangetop Performance**

Centre	2300 W
PowerBoost	•

**Safety**

Advanced cooling system	•
Anti-tilt bracket	•
Balanced oven door	•
Catalytic venting system	•
Child lock	•
CoolTouch door	•
Full extension telescopic sliding shelves	•
Non-tip shelves	•
Pan detection system	•
Safety time out	•
Spill containment	12 L
Spillage auto off	•
Surface hot indicators	•

**Warranty**

Parts and labour **2 years**

SKU 81695

The product dimensions and specifications in this page apply to the specific product and model. Under our policy of continuous improvement, these dimensions and specifications may change at any time. You should therefore check with Fisher & Paykel's Customer Care Centre to ensure this page correctly describes the model currently available. © Fisher & Paykel Appliances Ltd 2020

**Other product downloads available at fisherpaykel.com**

- [↓ Service & Warranty](#)
- [↓ Installation Guide Freestanding Cooker](#)
- [↓ Installation Guide - Kick Strip](#)
- [↓ Revit Freestanding Cooker](#)
- [↓ Rhino Freestanding Cooker](#)
- [↓ Sketchup Freestanding Cooker](#)
- [↓ User Guide Freestanding Cooker](#)

**Where applicable:**

All appliances use energy, and energy usage typically generates carbon emissions. **Fisher & Paykel Appliances' In-use Energy Carbon Emissions Estimate** indicates carbon emissions from a product's in-use energy. This is calculated either annually or per cycle, using the product's market-specific energy label energy consumption data multiplied by the carbon emissions factor for energy in your country or region.

Our In-use Energy Carbon Emissions Estimate is designed to assist customers in making informed purchasing decisions when comparing different Fisher & Paykel products. For example, a heat pump dryer typically has a lower In-use Energy Carbon Emissions Estimate than a vented dryer.



**A PEACE OF MIND SALE**  
**24 Hours 7 Days a Week Customer Support**  
 T 1300 650 590 Wwww.fisherpaykel.com