

48" Series 9 Professional 5 Burner + Griddle Dual Fuel Self-Cleaning Range, NG

Series 9 | Professional

Stainless Steel | Natural Gas



With intuitive touchscreen and specialized cooking functions across two ovens, this range is a stand-out addition to your kitchen.

- Guided cooking using your touchscreen makes it simple to cook by food, function or recipe.
- Gas cooktop with griddle and a top burner heat up to 23,500 BTU, for seriously fast boiling
- 6.9 cu ft total oven capacity across two oven cavities

- Ensure perfect results with the food probe, included

DIMENSIONS

Height	35 3/4 - 36 3/4 "
Width	47 7/8 "
Depth	29 1/8 "

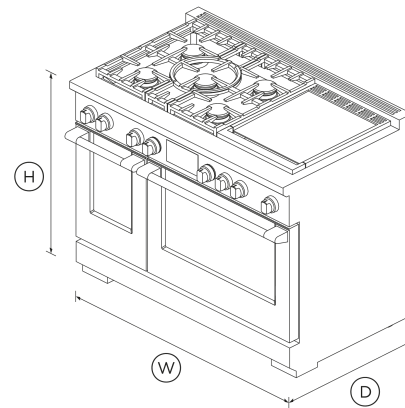

FEATURES & BENEFITS

Cook With Confidence

Our touchscreen interface provides an intuitive guided cooking experience that helps deliver perfect results, whether you've been cooking all your life or just starting out. Cook with a favorite method, a hero ingredient, or a go-to cooking function or recipe. The screen tilts for improved ergonomics and optimal visibility while cooking.

Generous Capacity

Two independently operating cavities provide a large total capacity of 4.8 cu. ft. in the main cavity and 2.1 cu. ft. in the secondary. That's enough room for a 32 lb turkey in one oven, and your sides in the other.

Cooking Flexibility

No matter what you're cooking, you've got the right heat to get perfect results. Each of the 15 oven functions in the main cavity and 11 in the secondary have been extensively researched and carefully designed to cater to a broad range of dishes and cooking styles. The handy food probe helps you monitor your progress.

Cooktop Power

Sealed dual flow burners deliver cooktop power up to 23,500 BTU for seriously fast boiling, and precise 140°F full surface, low temperature cooking with the gentlest of flames.

Design Quality

This range has craftsmanship in every detail, with real stainless steel, cast-iron grates, and beautifully weighted, halo illuminated dials. Each cavity features incandescent lights and full extension telescopic racks. From the robust legs to the powerful cooktop, this Range is built to last.

Easy To Clean

The oven features a self-cleaning function and self-clean proof side racks, which don't need to be removed when using this function.

SPECIFICATIONS

Accessories (included)

- Adjustable feet covers
- Branded coin end cap

Burner ratings

Maximum burner power	23500 BTU
Power back centre	23500BTU
Power back left	18500BTU
Power back right	18500BTU
Power front left	18500BTU
Power front right	18500BTU
Power griddle	24000BTU
Total cooktop power	121500 BTU

Capacity

Shelf positions (main oven)	5
Shelf positions (second oven)	5
Total capacity (main oven)	4.8 cu ft
Total capacity second oven	2.1 cu ft
Usable capacity (main oven)	3.8 cu ft

Cleaning

Easy clean porcelain basepan	•
Pyrolytic self-clean	•

Controls

Dial with illuminated halo	•
Dual control oven dials	•
Electric circuit	4 wire
High resolution display	•
Metal illuminated dials	•
Multi-language interface	•

Precise cooking with food probe	•
recipeAndFoodBasedFunctions	•
Sabbath mode	•
Smart appliance	•
Tilting touch screen interface	•

Gas Requirements

Fitting and pipe	½ NPT, min. 5/8" flex line
Supply Pressure (natural gas)	6" to 9" W.C

Main oven features

Concealed Element	•
Electronic oven control	•
Full extension telescopic racks	•
Internal light	•
Large broil pan	•
Self-clean proof side racks	•

Main oven functions

Air fry	•
Bake	•
Classic bake	•
Clean	•
Convection bake	•
Convection broil	•
Maxi broil	•
Number of oven functions	15
Pizza bake	•

Rapid proof	•
Roast	•
Slow cook	•
True convection	•
Warm	•

Oven features

Auto re-ignition system	•
Concealed element	•
Electronic oven control	•
Full extension telescopic sliding shelves	•
Internal light	true
Titanium coated, illuminated metal dials	•

Oven functions

Air fry	•
Bake	•
Classic bake	•
Clean	•
Convection bake	•
Convection Broil	•
Dehydrate	•
Dehydrate	•
Maxi Broil	•
Number of functions	15
Pastry bake	•
Pizza bake	•
Rapid proof	•
Roast	•

- Slow cook
- True convection
- Warm

Oven performance

Bake power	4600
Broil	3600 W
Main oven - True convection power	2500 W

Power Requirements

Connection	4-prong grounding type [NEMA 14-50 plug]
Service	50 A
Supply	120 / 240 V, 60 Hz

Product Details

Self Cleaning Sf	Yes
------------------	------------

Product Dimensions

Depth	29 1/8 "
Depth (excluding handles)	2918 mm
Height	35 3/4 - 36 3/4 "
Width	47 7/8 "

Rangetop features

- Sealed range top
- Vent trim included

Recommended Back Guards Ventilation

Combustible situation	BGRV3-3048H
Non combustible situation	BGRV2-3048 / BGRV2-1248
Recommended hood	HCB48-12_N (48" Professional Range Hood, Dual Blower)

Safety

- ADA compliant

Secondary oven features

- 3/4 Extension racks **2**
- Concealed element
- Electronic oven control
- Food probe
- Internal light

Secondary oven functions

- Air fry
- Bake
- Classic bake
- Convection bake
- Convection broil

- Maxi broil
- Number of secondary oven functions **11**
- Pastry bake
- Pizza bake
- Rapid proof
- Roast
- Warm

SKU 81894

The product dimensions and specifications in this page apply to the specific product and model. Under our policy of continuous improvement, these dimensions and specifications may change at any time. You should therefore check with Fisher & Paykel's Customer Care Centre to ensure this page correctly describes the model currently available. © Fisher & Paykel Appliances Ltd 2020

Other product downloads available at fisherpaykel.com

- [↓](#) 2D-DWG Dual Fuel Range
- [↓](#) 2D-DXF Dual Fuel Range
- [↓](#) ArchiCAD Dual Fuel Range
- [↓](#) Service & Warranty
- [↓](#) Installation Guide EN
- [↓](#) Installation Guide FR
- [↓](#) Planning Guide Professional Style Dial/Handle Accessories
- [↓](#) Planning Guide - 48" Professional Ranges & Backguards
- [↓](#) Revit Dual Fuel Range
- [↓](#) Rhino Dual Fuel Range
- [↓](#) SketchUp Dual Fuel Range
- [↓](#) User Guide EN

Where applicable:

All appliances use energy, and energy usage typically generates carbon emissions. **Fisher & Paykel Appliances' In-use Energy Carbon Emissions Estimate** indicates carbon emissions from a product's in-use energy. This is calculated either annually or per cycle, using the product's market-specific energy label energy consumption data multiplied by the carbon emissions factor for energy in your country or region.

Our In-use Energy Carbon Emissions Estimate is designed to assist customers in making informed purchasing decisions when comparing different Fisher & Paykel products. For example, a heat pump dryer typically has a lower In-use Energy Carbon Emissions Estimate than a vented dryer.

**A PEACE OF MIND SALE****24 Hours 7 Days a Week Customer Support**T 1.888.936.7872 W www.fisherpaykel.com