

# Freestanding French Door Refrigerator Freezer, 90cm, 545L

Series 7 | Contemporary

Stainless Steel | French hinge



With its large capacity you'll have plenty of flexible storage space in this French Door Refrigerator in stylish stainless steel.

- ActiveSmart™ technology to help keep food fresher for longer by stopping temperature fluctuation
- Spacious bottom freezer with full extension drawer gives easy access to frozen goods.

## DIMENSIONS

Height	1790 mm
Width	900 mm
Depth	695 mm

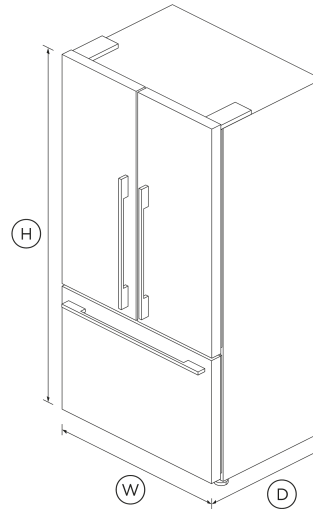

## FEATURES & BENEFITS

### Activesmart™ Foodcare

Every time you open your refrigerator, the temperature around your food changes. ActiveSmart™ foodcare adjusts airflow to create a stable temperature, helping your food stay fresher for longer.

### Simple Storage

This refrigerator is designed to make it simple for you to store, access and remove food. Storage bins give you full access inside when they're pulled open and can be easily removed to clean. Our flexible shelving also gives you more storage options.

### Humidity Control

Your fruit and veges need different environments. The humidity control slides in each storage bin create a microclimate that helps keep food fresher for longer.

### EASY CLEANING

No more permanent dirty marks with our EZKleen feature for stainless steel refrigerators. Anti-fingerprint coating means you simply wipe clean any marks. Spill-safe secure glass shelves easily capture any drips or leaks.

### Design Quality

Our refrigerators are designed and built using quality materials. We use real stainless steel, and solid glass for shelving.

### Clever Energy

Your refrigerator adapts to daily use by cooling and defrosting only when needed. This means it uses only the energy it needs without compromising on food care.

### COMPLEMENTARY DESIGN

With their premium handle styling and stainless steel finish, our refrigerators are designed to match the rest of Fisher & Paykel's kitchen appliance family.

## SPECIFICATIONS

### Capacity

Total gross capacity	614 L
Total net volume	536L
Volume freezer	127 L
Volume refrigerator	409 L

### Consumption

Energy consumption	<b>595kWh/year</b>
Energy rating	<b>2 ticks</b>
In-use energy carbon emissions estimate	<b>228.1kgCO2e/year</b>

Depth	<b>695 mm</b>
Height	<b>1790 mm</b>
Width	<b>900 mm</b>

**Where applicable:**

All appliances use energy, and energy usage typically generates carbon emissions. **Fisher & Paykel Appliances' In-use Energy Carbon Emissions Estimate** indicates carbon emissions from a product's in-use energy. This is calculated either annually or per cycle, using the product's market-specific energy label energy consumption data multiplied by the carbon emissions factor for energy in your country or region.

Our In-use Energy Carbon Emissions Estimate is designed to assist customers in making informed purchasing decisions when comparing different Fisher & Paykel products. For example, a heat pump dryer typically has a lower In-use Energy Carbon Emissions Estimate than a vented dryer.

**Features**

Adjustable door shelves	<b>6</b>
Adjustable glass shelves	<b>3</b>
Covered door shelves	<b>2</b>
Deli storage bins	<b>2</b>
Door alarm	<b>•</b>
Fruit and vegetable bins	<b>2</b>
SmartTouch control panel	<b>•</b>
Stackable bottle holders	<b>4</b>

**Warranty**

Parts and labour	<b>2 years</b>
Sealed system parts only	<b>5 years</b>

SKU 26181

The product dimensions and specifications in this page apply to the specific product and model. Under our policy of continuous improvement, these dimensions and specifications may change at any time. You should therefore check with Fisher & Paykel's Customer Care Centre to ensure this page correctly describes the model currently available. © Fisher & Paykel Appliances Ltd 2020

**Other product downloads available at fisherpaykel.com**

- [↓ 2D-DWG Freestanding French Door Fridge Freezer](#)
- [↓ Archicad Freestanding French Door Fridge Freezer](#)
- [↓ Data Sheet Freestanding French Door Fridge Freezer](#)
- [↓ Energy Label](#)
- [↓ Service & Warranty](#)
- [↓ Installation Guide](#)
- [↓ Installation Guide](#)
- [↓ Revit Freestanding French Door Fridge Freezer](#)
- [↓ Sketchup Freestanding French Door Fridge Freezer](#)
- [↓ User Guide](#)



**A PEACE OF MIND SALE**  
**24 Hours 7 Days a Week Customer Support**  
 T +65 6741 0777 W [www.fisherpaykel.com](http://www.fisherpaykel.com)

**Freezer Features**

Bottle chill	<b>•</b>
Door alarm	<b>•</b>
Fast freeze	<b>•</b>
Ice trays	<b>1</b>

**Performance**

ActiveSmart™ Foodcare	<b>•</b>
Adaptive defrost	<b>•</b>
Frost free freezer	<b>•</b>
Humidity control system	<b>•</b>
Sabbath mode	<b>•</b>

**Product dimensions**