

Combination Steam Oven, 76cm, 23 Function

Series 9 | Contemporary

Black



Our Combination Steam Oven is designed for the home chef, helping to effortlessly create healthy and delicious dishes. It pairs seamlessly with companion products such as the Vacuum Seal Drawer or Warming Drawer.

- 23 oven functions including Steam, Sous Vide, Air Fry and Crisp Regenerate
- With steam cooking, convection cooking, or a combination of both
- Pair with our Vacuum Seal Drawer companion product for effortless Sous Vide preparation

- Guided touchscreen cooking makes it simple to cook by food, function or recipe

DIMENSIONS

Height	458 mm
Width	760 mm
Depth	565 mm

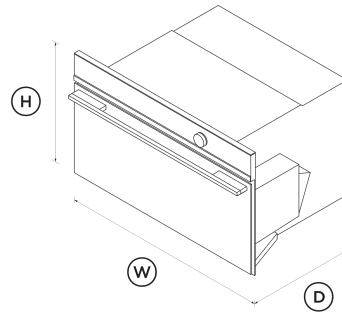

SPECIFICATIONS

Accessories (included)

Catalytic panels	•
Descal solution	2
Flat brushed baking tray	1
Full extension sliding shelves	1

Grill rack	1 set
Large steam dish	1
Perforated large steam dish	1
Perforated small steam dish	1
Roasting dish	1
Wire shelf	1
Wired temperature sensor	1

Capacity

Shelf positions	4
Total capacity	55 L
Usable capacity	45 L
Water tank capacity	1.4 L

Cleaning

- Acid resistant graphite enamel
- Descal cycle
- Drying cycle
- Easy to clean interior
- Removable oven door
- Removable oven door inner glass
- Removable shelf runners
- Removable water tank
- Steam clean (oven)

Functions

- Air fry
- Bake

- Classic bake
- Crisp regenerate
- Fan bake
- Fan forced
- Fan forced + High steam
- Fan forced + Low steam
- Fan forced + Medium steam
- Fan grill
- Grill
- Pastry Bake
- Pizza bake
- Roast
- Slow cook
- Sous vide
- Steam
- Steam clean (oven)
- Steam defrost
- Steam proof
- Steam regenerate
- Vent bake
- Warm

Height	458 mm
Width	760 mm
<hr/>	
SKU	84721



A PEACE OF MIND SALE
 24 Hours 7 Days a Week Customer Support
 T 1300 650 590 Wwww.fisherpaykel.com

The product dimensions and specifications in this page apply to the specific product and model. Under our policy of continuous improvement, these dimensions and specifications may change at any time. You should therefore check with Fisher & Paykel's Customer Care Centre to ensure this page correctly describes the model currently available. © Fisher & Paykel Appliances Ltd 2020

Other product downloads available at fisherpaykel.com

- [↓](#) 2D-DWG Combination Steam Oven
- [↓](#) Service & Warranty
- [↓](#) Planning Guide - 76cm Built-in Ovens and Companions - Contemporary Black

Where applicable:

All appliances use energy, and energy usage typically generates carbon emissions. **Fisher & Paykel Appliances' In-use Energy Carbon Emissions Estimate** indicates carbon emissions from a product's in-use energy. This is calculated either annually or per cycle, using the product's market-specific energy label energy consumption data multiplied by the carbon emissions factor for energy in your country or region.

Our In-use Energy Carbon Emissions Estimate is designed to assist customers in making informed purchasing decisions when comparing different Fisher & Paykel products. For example, a heat pump dryer typically has a lower In-use Energy Carbon Emissions Estimate than a vented dryer.

Power requirements

Amperage	20 A
Supply frequency	50 Hz
Supply voltage	220-240 V

Product dimensions

Depth	565 mm
-------	--------