

# Combination Steam Oven, 24", 9 Function

Series 9 | Contemporary

Stainless Steel



Reduce the need for oils and fats with steam cooking. Its compact size makes this perfect to pair with a warming drawer underneath.

- 1.3 cu ft total capacity
- Cooking flexibility with nine oven functions, including five Steam functions, Broil and Convection
- Steam cooking allows you to cook a food in its own juices, to retain nutrients and flavour

- Designed to match aesthetically with companion products such as warming drawers, for flexible cooking configurations

## DIMENSIONS

Height	18 1/16 "
Width	23 7/16 "
Depth	22 1/8 "

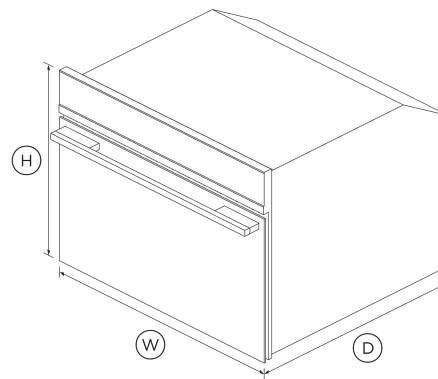

## FEATURES & BENEFITS

### SIZED TO SUIT

This compact 24" Steam Oven can be placed almost anywhere. All Companion products can be installed at a convenient height to suit your kitchen design and preference.

### SIMPLE TO USE

An easy to use, intuitive display shows the time and provides useful information about functions along with a refill alert.

### EASY CLEANING

Cleaning and care of the Steam Oven is simple. After each use, just wipe the smooth stainless steel interior with a dry cloth.

### SAFE & SOUND

The CoolTouch door is safe to touch from the outside, protecting your hands and the surrounding cabinetry.

### EASY INSTALLATION

Plug in and cook straight away. The Steam Oven is easy to install, with no plumbing needed.

### HEALTHY EATING

The Steam Oven allows you to cook food in its own juices to retain nutrients and flavor. With nine oven modes, it doesn't just steam, but also has Broil and Fan functions.

## SPECIFICATIONS

### Accessories (included)

Baking pan	1
Perforated large steam dish	1
Wire shelf	1
Wired temperature sensor	1

### Accessories (sold separately)

Matching Trim Kit	TK30NDB1
Optional lower trim kit	Part 81662

### Capacity

Shelf positions	3
Total capacity	1.3 cu ft

**Cleaning**

Easy clean stainless steel interior	•
Removable water tank	•
Steam clean (oven)	•

**Consumption**

Energy usage	141kWh/year
In-use energy carbon emissions estimate	17.4kgCO2e/year

**Controls**

Audio feedback	•
Automatic cooking/minute timer	•
Celsius/Fahrenheit temperature	•
Delay start	•
Electronic clock	•
Electronic oven control	•
Food probe	•
Guided cooking by food type and recipes	•
Halogen lights	•
Intuitive touchscreen display	•

**Functions**

Broil	•
Convection Broil	•

Number of functions	9
Recipe function	•
Ring + broil	•
Steam + ring	•
Steam 100 (100°C / 210°F)	•
Steam 130 (130°C / 265°F)	•
Steam assist	•
Steam clean (oven)	•

**Performance**

Broil power	1500 W
SteamTechnology	•

**Power requirements**

Amperage	15 A
Supply frequency	60 Hz
Supply voltage	120/208-120/240 V

**Product dimensions**

Depth	22 1/8 "
Height	18 1/16 "
Width	23 7/16 "

**Safety**

Control panel key lock	•
CoolTouch door	•
Safety thermostat	•

SKU 82308

The product dimensions and specifications in this page apply to the specific product and model. Under our policy of continuous improvement, these dimensions and specifications may change at any time. You should therefore check with Fisher & Paykel's Customer Care Centre to ensure this page correctly describes the model currently available. © Fisher & Paykel Appliances Ltd 2020

**Other product downloads available at fisherpaykel.com**

- [↓](#) 2D-DWG Combination Steam Oven with 30" Trim
- [↓](#) 2D-DWG Combination Steam Oven with Bottom Trim
- [↓](#) 2D-DWG Combination Steam Oven
- [↓](#) 2D-DXF Combination Steam Oven with 30" Trim
- [↓](#) 2D-DXF Combination Steam Oven with Bottom Trim
- [↓](#) 2D-DXF Combination Steam Oven
- [↓](#) Archicad Combination Steam Oven
- [↓](#) Archicad Combination Steam Oven with 24" Trim
- [↓](#) Archicad Combination Steam Oven with 30" Trim
- [↓](#) Data Sheet Combination Steam Oven with 30" Trim
- [↓](#) Data Sheet Combination Steam Oven with Bottom Trim
- [↓](#) Data Sheet Combination Steam Oven
- [↓](#) Service & Warranty
- [↓](#) Installation Guide Companion Products EN
- [↓](#) Guide d'installation FR
- [↓](#) Installation Guide - Cavity Trim Kit
- [↓](#) Revit Combination Steam Oven
- [↓](#) Revit Combination Steam Oven with 24" Trim
- [↓](#) Revit Combination Steam Oven with 30" Trim
- [↓](#) Rhino Combination Steam Oven
- [↓](#) Rhino Combination Steam Oven 24" Trim
- [↓](#) Rhino Combination Steam Oven with 30" Trim
- [↓](#) Sketchup Combination Steam Oven

- [↓ Sketchup Combination Steam Oven 24" Trim](#)
- [↓ Sketchup Combination Steam Oven with 30" Trim](#)
- [↓ Specification Guide Combination Steam Oven](#)
- [↓ User Guide EN](#)

**Where applicable:**

All appliances use energy, and energy usage typically generates carbon emissions. **Fisher & Paykel Appliances' In-use Energy Carbon Emissions Estimate** indicates carbon emissions from a product's in-use energy. This is calculated either annually or per cycle, using the product's market-specific energy label energy consumption data multiplied by the carbon emissions factor for energy in your country or region.

Our In-use Energy Carbon Emissions Estimate is designed to assist customers in making informed purchasing decisions when comparing different Fisher & Paykel products. For example, a heat pump dryer typically has a lower In-use Energy Carbon Emissions Estimate than a vented dryer.



**A PEACE OF MIND SALE**  
**24 Hours 7 Days a Week Customer Support**  
T 1.888.936.7872 W [www.fisherpaykel.com](http://www.fisherpaykel.com)