

# Convection Speed Oven, 30", 22 Function

Series 9 | Contemporary

Stainless Steel



The speed of microwave cooking with the versatility of convection oven technology, designed for perfect pairing with other companion products such as a steam oven or warming drawer.

- Generous 1.7 cu ft capacity, with four shelf positions
- With four microwave-only functions, 14 traditional oven functions, and four combination functions
- Guided touchscreen cooking makes it simple to navigate cooking processes

- Wi-Fi enabled and works with the SmartHQ™ app for remote control and notifications

## DIMENSIONS

Height	18 "
Width	29 15/16 "
Depth	22 1/4 "

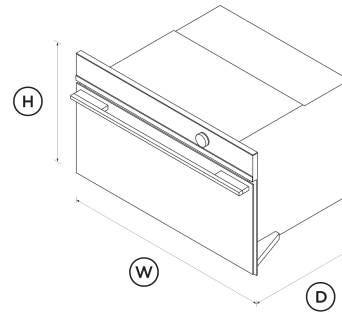

## FEATURES & BENEFITS

### Cooking flexibility

Choose from 22 functions, including four microwave-only functions, 14 traditional oven functions, and four combination functions, giving you the best microwave and convection oven technology.

### Cook with confidence

The large touchscreen provides an intuitive guided cooking experience that helps to deliver perfect results, whether you've been cooking all your life or are just starting out.

### Sized to suit

As a companion product this microwave oven is designed to be placed almost anywhere – fitting perfectly with a steam oven or other companion products to create a suite of kitchen appliances at your fingertips, and for your convenience.

### Easy to use

The intuitive touch display shows you all the information you need, allowing you to easily program in your desired cooking mode and duration.

### Safe and sound

The CoolTouch door is safe to touch from the outside, protecting your hands and the surrounding cabinetry.

## SPECIFICATIONS

### Cleaning

- Acid resistant graphite enamel
- Drying cycle
- Easy to clean interior
- Removable shelf runners

### Controls

- Adjustable audio and display settings
- Audio feedback
- Automatic cooking/minute timer
- Automatic pre-set temperatures
- Celsius/Fahrenheit temperature
- Delay start

Dial with illuminated halo	•
Electronic capacitive touch controls	•
Electronic clock	•
Electronic oven control	•
Food probe	•
Guided cooking by food type and recipes	•
Halogen lights	•
Intuitive touchscreen display	•
Microwave timer	•
Multi-language display	<b>true</b>
Push-to-open drawer	•
Sabbath mode with Star K certification	•
Smart appliance	•
Soft close doors	•
Touch control glass interface	•
True convection oven	•
Turned stainless steel dials with illuminated halos	•
Wi-Fi connectivity	•

The product dimensions and specifications in this page apply to the specific product and model. Under our policy of continuous improvement, these dimensions and specifications may change at any time. You should therefore check with Fisher & Paykel's Customer Care Centre to ensure this page correctly describes the model currently available. © Fisher & Paykel Appliances Ltd 2020

**Other product downloads available at fisherpaykel.com**

- [↓](#) 2D-DWG Combination Microwave Oven
- [↓](#) 2D-DXF Combination Microwave Oven
- [↓](#) Service & Warranty
- [↓](#) Planning Guide - Contemporary 30" Built-in Ovens and Companions

**Where applicable:**

All appliances use energy, and energy usage typically generates carbon emissions. **Fisher & Paykel Appliances' In-use Energy Carbon Emissions Estimate** indicates carbon emissions from a product's in-use energy. This is calculated either annually or per cycle, using the product's market-specific energy label energy consumption data multiplied by the carbon emissions factor for energy in your country or region.

Our In-use Energy Carbon Emissions Estimate is designed to assist customers in making informed purchasing decisions when comparing different Fisher & Paykel products. For example, a heat pump dryer typically has a lower In-use Energy Carbon Emissions Estimate than a vented dryer.

<b>Product dimensions</b>	
Depth	<b>22 1/4 "</b>
Height	<b>18 "</b>
Width	<b>29 15/16 "</b>
<hr/>	
SKU	82687



**A PEACE OF MIND SALE**  
 24 Hours 7 Days a Week Customer Support  
 T 1.888.936.7872 W [www.fisherpaykel.com](http://www.fisherpaykel.com)