

# Condensing Dryer, 8kg

Series 5 | Condensing

White



With no need to vent moisture outside, you can incorporate the condensing dryer into any laundry design to create a beautiful laundry space anywhere in your home.

- This machine offers 13 dry cycles including Freshen, Heavy and Easy Iron for to cater for every type of load.
- It also monitors moisture levels to prevent under or over-drying using Auto-sensing technology.
- Provides an internal drying rack for items too precious to tumble.
- Interior drum light for increased visibility while unloading.

## DIMENSIONS

Height	850 mm
Width	600 mm
Depth	645 mm

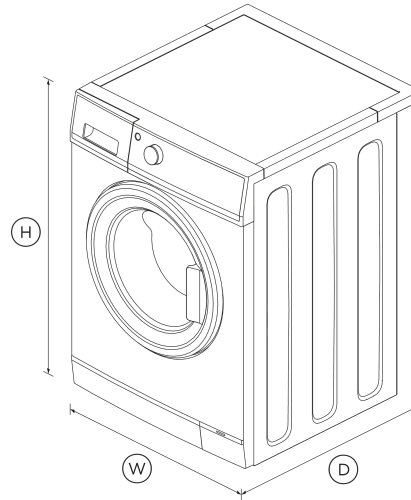

## FEATURES & BENEFITS

### Cares For Clothes

13 drying cycles including Freshen, Heavy and Easy Iron for every type of garment. Select the cycle that best suits your load from delicates to sheets to confidently dry your laundry.

### Avoid Over-Drying With Auto-Sensing

Auto-sensing technology measures moisture inside the drum, shutting off at the perfect time to avoid over-drying your clothes. It helps them last longer and reduces energy wastage.

### Too Precious To Tumble?

The drying rack is designed for items that can't be tumble dried. It fits easily into the dryer and delivers the perfect result for those precious delicates, shoes and toys.

### No Venting Required

Condensation is collected so there is no need for external venting, allowing your dryer to be placed almost anywhere in your home.

### Drum Light

A handy interior light turns on when you open the dryer door providing improved visibility inside the drum.

### Designed To Match

The complete package for a beautiful laundry. This 8kg Condensing Dryer is designed to match with our Front Loader Washing Machines. With outstanding aesthetics and complimentary wash and dry cycles, they become the perfect pair to deliver complete fabric care.

## SPECIFICATIONS

### Capacity

Total capacity **8 kg**

### Consumption

Energy rating **2 star**  
 Energy usage **355kWh/year**  
 In-use energy carbon emissions estimate **48.1kgCO2e/year**

### Dry Cycles

Cool air •

Delicate	•	Auto sensing	•
Easy Iron	•	Condensing	•
Everyday	•	Dryness settings	5
Heavy	•	Reverse tumbling	•
Number of cycles	11	Temperature settings	4
Rack dry	•	Time dry	30, 60, 90 mins
Sheets	•		
Time to dry 30	•		
Time to dry 60	•		
Time to dry 90	•		

**Features**

Child/Keylock	•
Clean door lint filter reminder	•
Damp dry signal	•
Drain hose	included
Drum light	•
Drying rack	•
Easy access lint filter	•
End of cycle signal	•
No external venting	•
Progress indicator	•
Removable water tank	•
SmartTouch™ control dial	•
Stainless steel drum	•
Time to go	•
Wrinkle free option	•

**Performance**

**Product dimensions**

Depth	645 mm
Height	850 mm
Width	600 mm

**Warranty**

Parts and labour	2 years
------------------	---------

SKU	93280
-----	-------

The product dimensions and specifications in this page apply to the specific product and model. Under our policy of continuous improvement, these dimensions and specifications may change at any time. You should therefore check with Fisher & Paykel's Customer Care Centre to ensure this page correctly describes the model currently available. © Fisher & Paykel Appliances Ltd 2020

**Other product downloads available at [fisherpaykel.com](http://fisherpaykel.com)**

- [↓](#) Energy Label Condensing Dryer
- [↓](#) Service & Warranty
- [↓](#) Installation & User Guide

**Where applicable:**

All appliances use energy, and energy usage typically generates carbon emissions. **Fisher & Paykel Appliances' In-use Energy Carbon Emissions Estimate** indicates carbon emissions from a product's in-use energy. This is calculated either annually or per cycle, using the product's market-specific energy label energy consumption data multiplied by the carbon emissions factor for energy in your country or region.

Our In-use Energy Carbon Emissions Estimate is designed to assist customers in making informed purchasing decisions when comparing different Fisher & Paykel products. For example, a heat pump dryer typically has a lower In-use Energy Carbon Emissions Estimate than a vented dryer.



**A PEACE OF MIND SALE**  
**24 Hours 7 Days a Week Customer Support**  
 T 0800 372 273 W [www.fisherpaykel.com](http://www.fisherpaykel.com)