

Oven, 30" 17 Function, Self-cleaning

Series 7 | Contemporary

Stainless Steel



With beautiful Contemporary styling and a generous 4.1 cu ft total capacity, this built-in oven helps to ensure that every dish you create is cooked to perfection.

- 4.1 cu ft total capacity with 17 oven functions including Air Fry and Dehydrate
- Even heat circulation with AeroTech™, ideal for multi-shelf cooking
- Pyrolytic self-cleaning function breaks down food residue for an easy clean

- Guided cooking capability offers helpful tips for different food types

DIMENSIONS

Height	27 3/16 "
Width	29 15/16 "
Depth	23 15/16 "

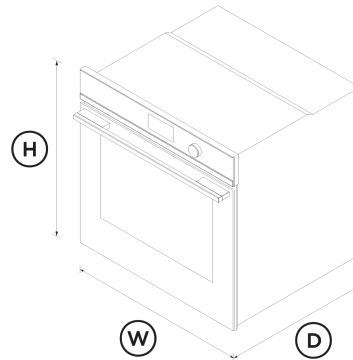

FEATURES & BENEFITS

Multi-Function Flexibility

Each function has been perfected to ensure that no matter what you're cooking, you've got the right heat to match. This built-in oven has 17 functions including Pastry Bake, Roast, Fan Grill, Dehydrate and Rapid Proof, allowing you to use a variety of cooking styles.

Generous Capacity

With an incredible 4.1 cu ft total capacity in each oven, you can create several perfectly cooked dishes at once using multiple shelves.

Cook With Confidence

The intuitive 2.4" screen provides an intuitive guided cooking experience that helps to deliver perfect results, whether you've been cooking all your life or are just starting out. Cook by food type and allow your oven to guide you through steps, or change temperature and heat type automatically, depending on your selection.

Exceptional Performance

AeroTech™ circulates heat evenly for a consistent temperature throughout the cavity, helping you ensure perfect results even when cooking on multiple shelves.

Self-Cleaning

Pyrolytic self-clean breaks down food residue at a very high temperature, leaving a light ash that's easily removed with a damp cloth. The enamel coated side racks don't need to be removed when using this function.

Design Freedom

Designed to fit seamlessly into your kitchen, this built-in oven features premium materials and detailing to support a cohesive, considered kitchen design.

Safe And Sound

The CoolTouch door features triple glazing and a cooling system that ensures it's safe to touch from the outside - protecting both your hands and the surrounding cabinetry.

SPECIFICATIONS

Accessories (included)

Broil grid

1

Broil pan	1
Broil rack	1
Full extension sliding shelves	2
Pyrolytic proof shelf runners	•
Wired temperature sensor	1

Capacity

Total capacity	4.1 cu ft
----------------	------------------

Cleaning

Acid resistant graphite enamel	•
Pyrolytic proof shelf runners	•
Pyrolytic self-clean	•
Removable oven door	•
Removable shelf runners	•

Consumption

Energy usage	376kWh/year
In-use energy carbon emissions estimate	46.4kgCO2e/year

Controls

Adjustable audio and display settings	•
Audio feedback	•
Automatic cooking/minute timer	•
Automatic pre-set temperatures	•
Celsius/Fahrenheit temperature	•
Delay start	•

Electronic clock	•
Electronic oven control	•
Food probe	•
Halogen lights	•
Intuitive touchscreen display	•
Multi-language display	•

UK English, US English, Simplified Chinese, Français, Español

Sabbath mode with Star K certification	•
Smart appliance	•
Soft close doors	•
True convection oven	•
Turned stainless steel dials with illuminated halos	•
Wi-Fi connectivity	•

Functions

Aero Broil	•
Aero™ Bake	•
Air fry	•
Bake	•
Broil	•
Classic bake	•
Dehydrate	•
Maxi Broil	•
Number of functions	17
Pastry Bake	•
Pizza bake	•
Pyrolytic self-clean	•
Rapid proof	•

Roast	•
Slow cook	•
True Aero	•
Vent bake	•
Warm	•

Performance

ActiveVent™ system	•
AeroTech™ technology	•
Automatic rapid pre-heat	•
Broil power	4400 W
Temperature range	95 °F - 540 °F

Power requirements

Amperage	16.6 - 19.4 A
Supply frequency	60 Hz
Supply voltage	208 - 240 V

Product dimensions

Depth	23 15/16 "
Height	27 3/16 "
Width	29 15/16 "

Safety

Balanced oven door	•
Catalytic venting system	•
Control panel key lock	•

CoolTouch door	•
Non-tip shelves	•
Safety thermostat	•

- [↓](#) Guide d'utilisation FR
- [↓](#) Guía del usuario ES

Warranty

Parts and labor	2 years
-----------------	----------------

SKU	82578
-----	-------

The product dimensions and specifications in this page apply to the specific product and model. Under our policy of continuous improvement, these dimensions and specifications may change at any time. You should therefore check with Fisher & Paykel's Customer Care Centre to ensure this page correctly describes the model currently available. © Fisher & Paykel Appliances Ltd 2020

Where applicable:

All appliances use energy, and energy usage typically generates carbon emissions. **Fisher & Paykel Appliances' In-use Energy Carbon Emissions Estimate** indicates carbon emissions from a product's in-use energy. This is calculated either annually or per cycle, using the product's market-specific energy label energy consumption data multiplied by the carbon emissions factor for energy in your country or region.

Our In-use Energy Carbon Emissions Estimate is designed to assist customers in making informed purchasing decisions when comparing different Fisher & Paykel products. For example, a heat pump dryer typically has a lower In-use Energy Carbon Emissions Estimate than a vented dryer.



A PEACE OF MIND SALE

24 Hours 7 Days a Week Customer Support

T 1.888.936.7872 W www.fisherpaykel.com

Other product downloads available at fisherpaykel.com

- [↓](#) 2D - DWG Oven
- [↓](#) 2D - DXF Oven
- [↓](#) ArchiCAD Oven
- [↓](#) Energy Label Oven
- [↓](#) Service & Warranty
- [↓](#) Installation Guide EN / Guide d'installation FR
- [↓](#) Installation Guide Wall Oven EN
- [↓](#) Planning Guide - Contemporary 30" Built-in Ovens and Companions
- [↓](#) Revit Oven
- [↓](#) Rhino Oven
- [↓](#) SketchUp Oven
- [↓](#) User Guide Oven EN